

# T-8421D

# T-8422D

---

2本針本縫ダイレクトドライブミシン

2本針本縫ダイレクトドライブ自動糸切りミシン

TWIN NEEDLE DIRECT DRIVE LOCK STITCHER

TWIN NEEDLE DIRECT DRIVE LOCK STITCHER WITH THREAD TRIMMER

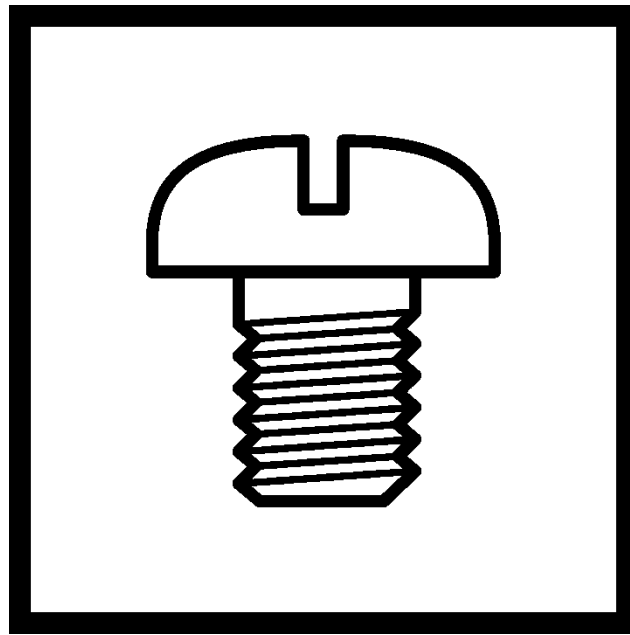

---

**brother**

## 型式板の見方

< 糸切りなし >

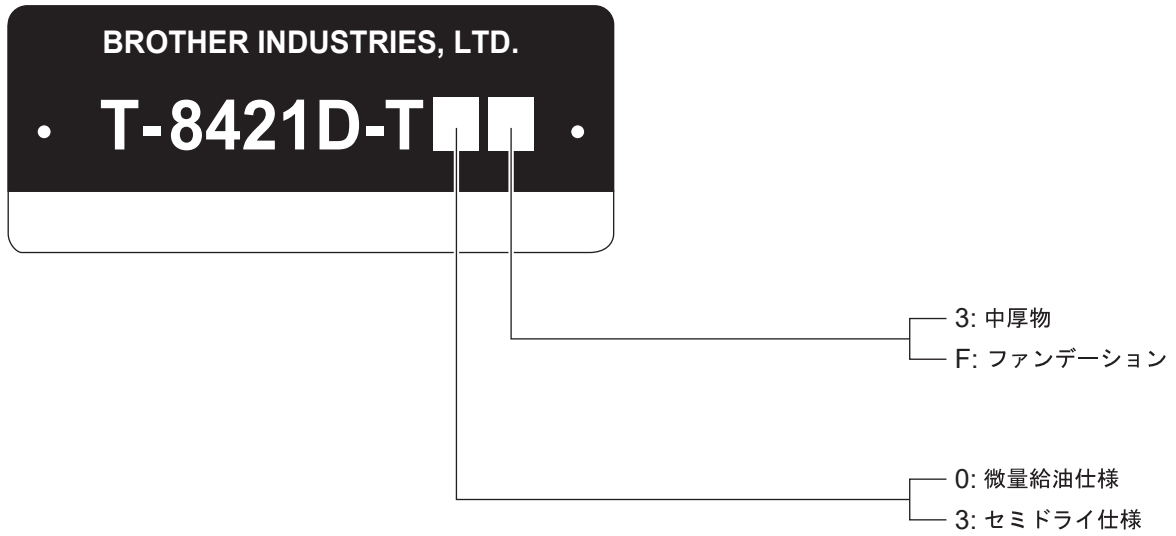

< 揺動式糸切り >

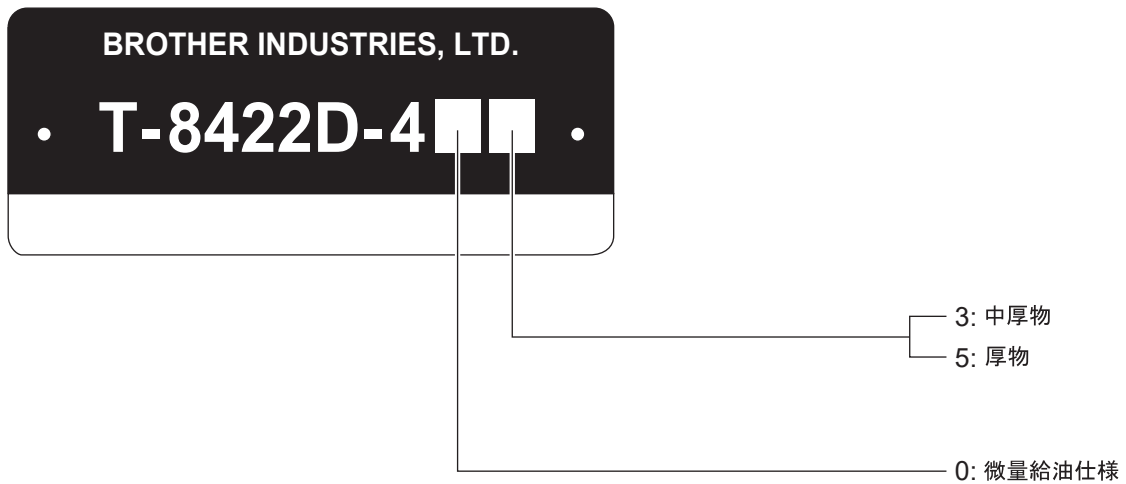

< 直動式糸切り >

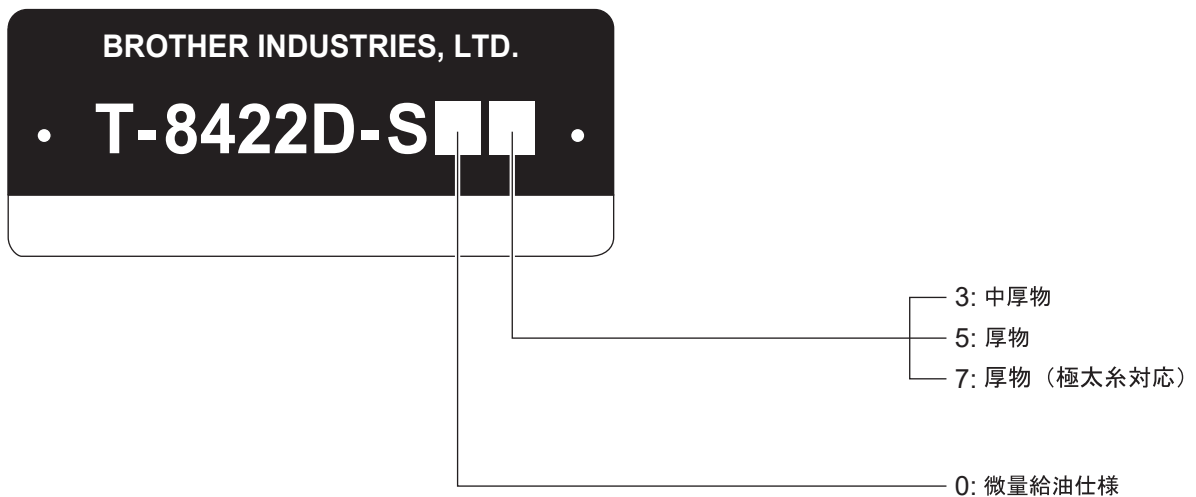

## Description of model plate

### <Without thread trimmer>

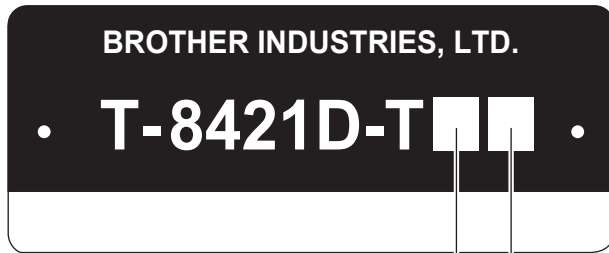

3: Medium-weight materials  
F: Foundation garments

0: Minimum lubrication type  
3: Semi dry type

### <Arc type thread trimmer>

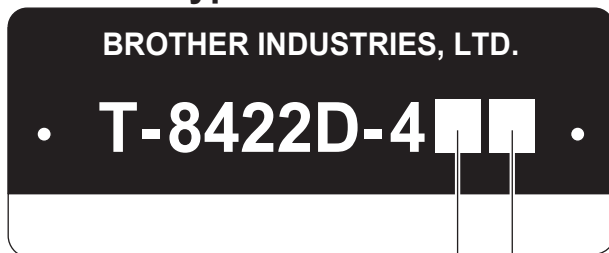

3: Medium-weight materials  
5: Heavy-weight materials

0: Minimum lubrication type

### <Straight type thread trimmer>

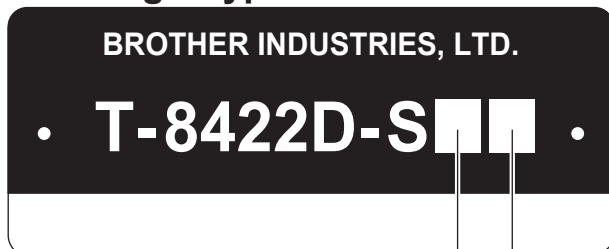

3: Medium-weight materials  
5: Heavy-weight materials  
7: Heavy-weight materials  
(For extra thick thread)

0: Minimum lubrication type

# パーツブックご利用に際して

1. この本は、2020年6月のデータに基づいて作成されたものです。
2. 部品は予告なしに設計変更される場合があります。
3. 組単位で補給する部品は、破線で示してあります。
4. イラスト中で数字(REF.NO)に“+”がついている部品は、仕様により異なります。  
詳細は、リストを参照してください。

## 目 次

A. 主体関係 .....	1
B. 上軸関係 .....	3
C. 針棒揺動関係 .....	5
D. 押え関係 .....	7
E. 送り関係 .....	9
F. 逆転関係 .....	11
G. 送り軸関係 .....	13
H. ゲージ関係 .....	15
J1. かま関係 (T-8421D) .....	17
J2. かま関係 (T-8422D-40□) .....	19
J2. かま関係 (T-8422D-S0□) .....	23
J3. かま関係 .....	27
K. 下軸関係 .....	29
L. 給油潤滑関係 .....	31
M. 糸通し関係 .....	35
N. 糸巻関係 .....	37
P. 糸切り関係 .....	39
Q. 糸緩め関係 (T-8422D) .....	43
R. 糸払い関係 (T-8422D) .....	45
S1. コントロールボックス関係 .....	47
S2. コントロールボックス関係 .....	49
T. 逆転スイッチ関係 .....	51
U. 操作パネル関係 .....	53
V. 電装品・モーター関係 .....	55
Z1. 付属品関係 .....	57
Z2. 付属品関係 .....	59
Wa. 警告ラベル .....	61
Sp. 仕様別部品一覧表 .....	63
Ga1. ゲージ部品一覧表 (T-8421D) .....	65
Ga2. ゲージ部品一覧表 (T-8422D-40□) .....	69
Ga2. ゲージ部品一覧表 (T-8422D-S0□) .....	71
索引 .....	73

# Notes for using this parts book

1. This book was prepared based on information available in June 2020.
2. Parts are subject to changes in design without prior notice.
3. Parts supplied as complete assemblies are circled by a dotted line.
4. The part which has the symbol "+" on its number (REF.NO) in the figure differs depending on the specification. For details, refer to the parts list.

## CONTENTS

A. Machine body .....	1
B. Upper shaft mechanism .....	3
C. Needle bar rocking mechanism .....	5
D. Presser foot mechanism .....	7
E. Feed mechanism .....	9
F. Quick reverse mechanism .....	11
G. Feed shaft mechanism .....	13
H. Gauge parts .....	15
J1. Rotary hook mechanism (T-8421D) .....	17
J2. Rotary hook mechanism (T-8422D-40[]) .....	19
J2. Rotary hook mechanism (T-8422D-S0[]) .....	23
J3. Rotary hook mechanism .....	27
K. Lower shaft mechanism .....	29
L. Lubrication .....	31
M. Threading mechanism .....	35
N. Bobbin winder mechanism .....	37
P. Thread trimmer mechanism .....	39
Q. Tension release mechanism (T-8422D) .....	43
R. Thread wiper mechanism (T-8422D) .....	45
S1. Control box .....	47
S2. Control box .....	49
T. Quick reverse switch mechanism .....	51
U. Operation panel .....	53
V. Power supply equipment and motor mechanism .....	55
Z1. Accessories .....	57
Z2. Accessories .....	59
Wa. Warning labels .....	61
Sp. Different parts list .....	63
Ga1. Gauge parts list (T-8421D) .....	65
Ga2. Gauge parts list (T-8422D-40[]) .....	69
Ga2. Gauge parts list (T-8422D-S0[]) .....	71
Index .....	73

A. 主体関係 / Machine body

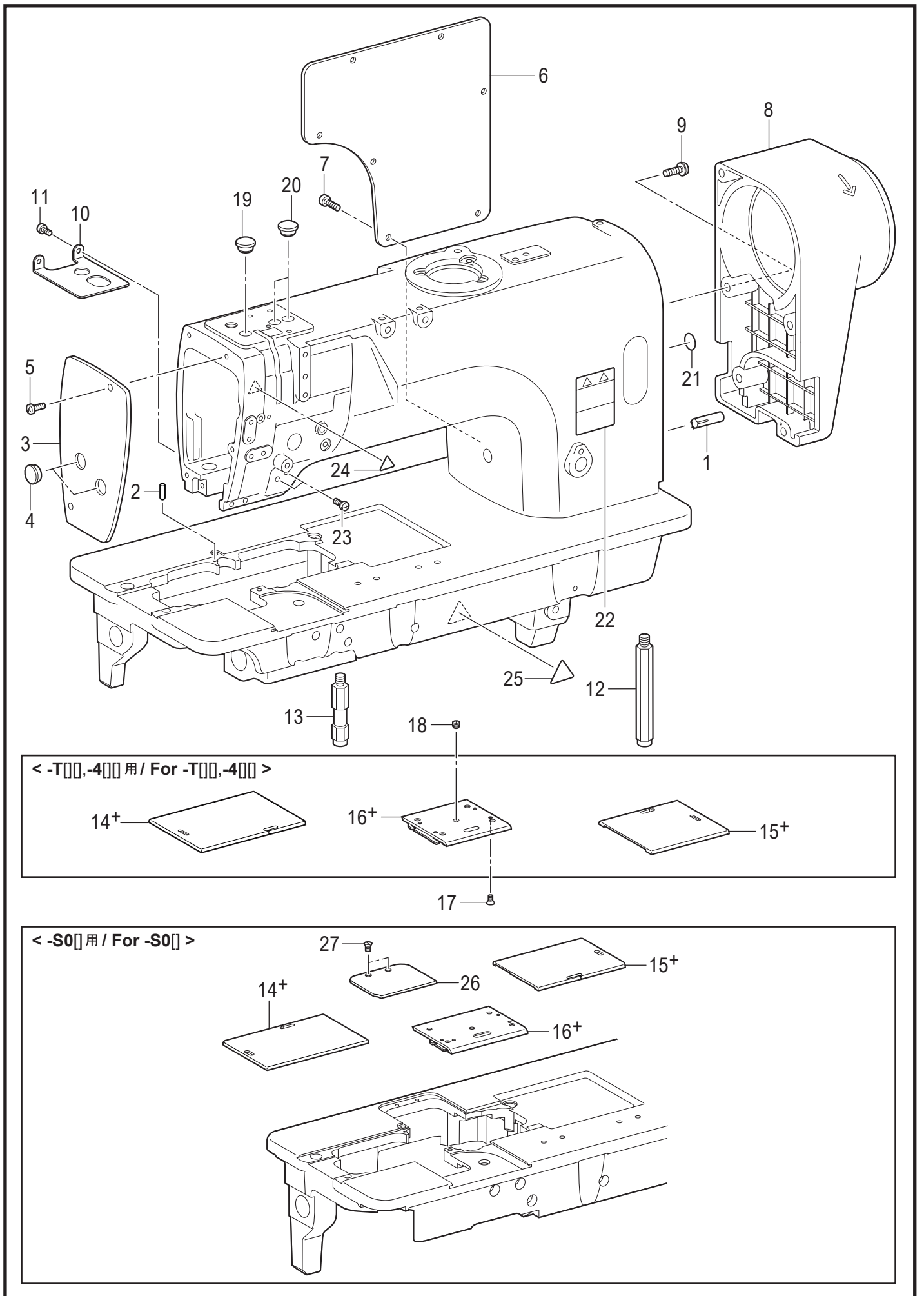

T-8421D/8422D-050

A. 主体関係 / Machine body

REF.NO	CODE	Q'TY	品名	NAME OF PARTS	RM
1	140063001	2	ミヅツキピン	DOWEL PIN	
2	SA3924001	1	ハリイタイチキメピン	POSITIONING PIN	
3	SB9859001	1	メンイタ	FACE PLATE	
4	SA2929001	2	ゴムセン12.5	RUBBER CAP, 12.5	
5	062500816	2	ナベコ5X8	SCREW PAN M5X8	
6	SA2441201	1	ガワイタ	REAR COVER	
7	062501216	7	ナベコ5X12	SCREW PAN M5X12	
8	SB9863001	1	モータカバー	MOTOR COVER	
9	SA9977101	5	ナベザクミ5X18	SCREW PAN M5X18	
10	SA2443101	1	ダストプレート	DUST PROTECTOR	
11	062500616	2	ナベコ5X6	SCREW PAN M5X6	
12	SA2444101	1	キヤクチュウL	BED LEG L	
13	SA2445101	1	キヤクチュウS	BED LEG S	
17	S34438001	4	サラネジ3.18X4	SCREW FLAT SM3.18-40X4	
18	116010001	1	トメネジ5.16	SET SCREW, SM5.16-40X4	
19	SA2929001	1	ゴムセン12.5	RUBBER CAP, 12.5	
20	SA2929001	2	ゴムセン12.5	RUBBER CAP, 12.5	
21	S37060001	1	ア-スマーク	LABEL GROUNDING	
22	SA9826001	1	ソウサチュウイラベル	LABEL CAUTION	
23	062500816	2	ナベコ5X8	SCREW PAN M5X8	
24	SA9957001	1	ワ-ニングマーク	INJURY MARK	
25	SA9957002	1	ワ-ニングマーク	INJURY MARK	
			<-T□□,-4□□用>	<For -T□□,-4□□>	
14+	SA2448201	1	スベリイタLA	SLIDE PLATE LA	
15+	SA2450201	1	スベリイタR	SLIDE PLATE R	
16+	S36663101	1	スベリイタFクミ	SLIDE PLATE F ASSY	
			<-S0□用>	<For -S0□>	
14+	SC0746001	1	スベリイタLA	SLIDE PLATE LA	
15+	SC0747001	1	スベリイタR	SLIDE PLATE R	
16+	SC0748001	1	スベリイタFクミ	SLIDE PLATE F ASSY	
26	SC0718001	1	スベリイタB	SLIDE PLATE B	
27	108960002	2	サラネジ3.57	SCREW, FLAT SM3.57	

B. 上軸関係 / Upper shaft mechanism

< 微量給油仕様 -[0]用 / For -[0] Minimum lubrication type >

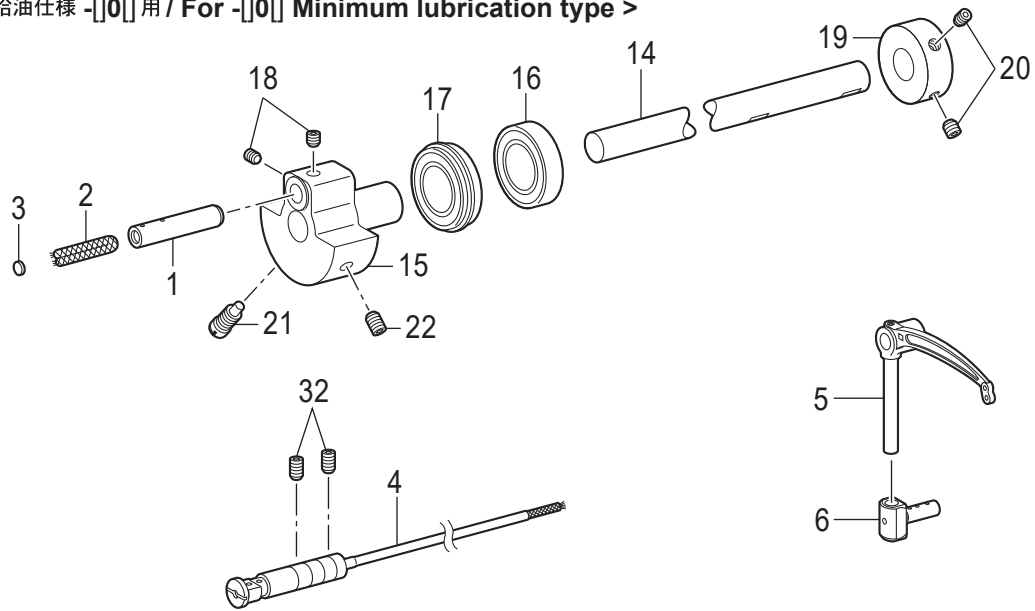

< セミドライ仕様 -T3F用 / For -T3F Semi dry type >

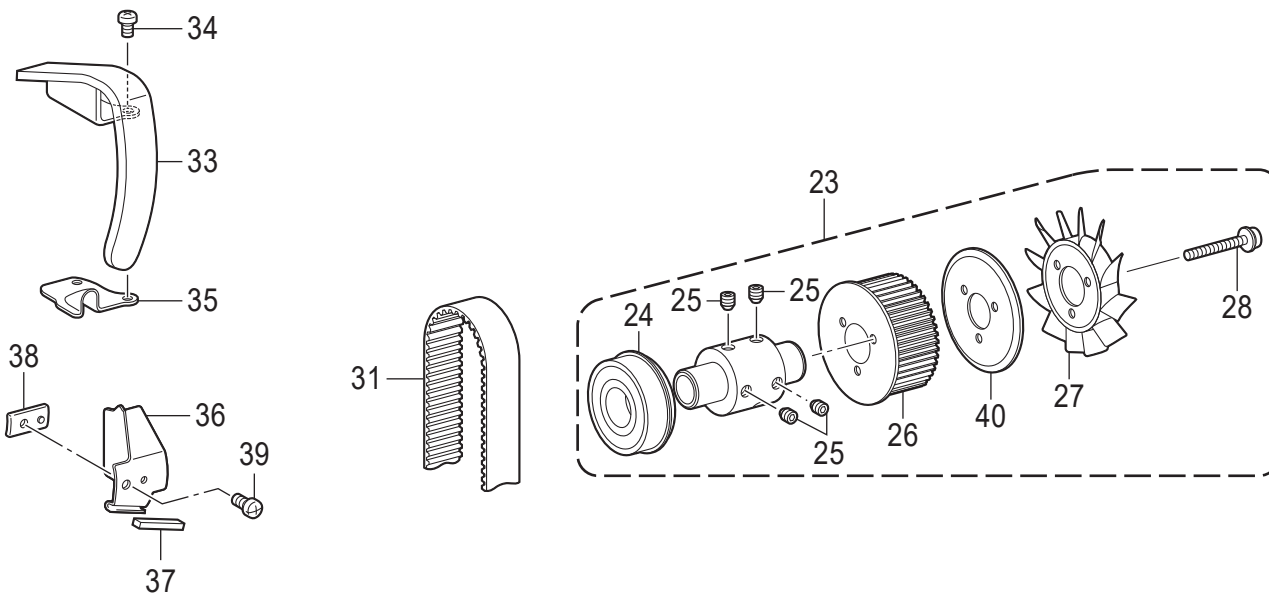
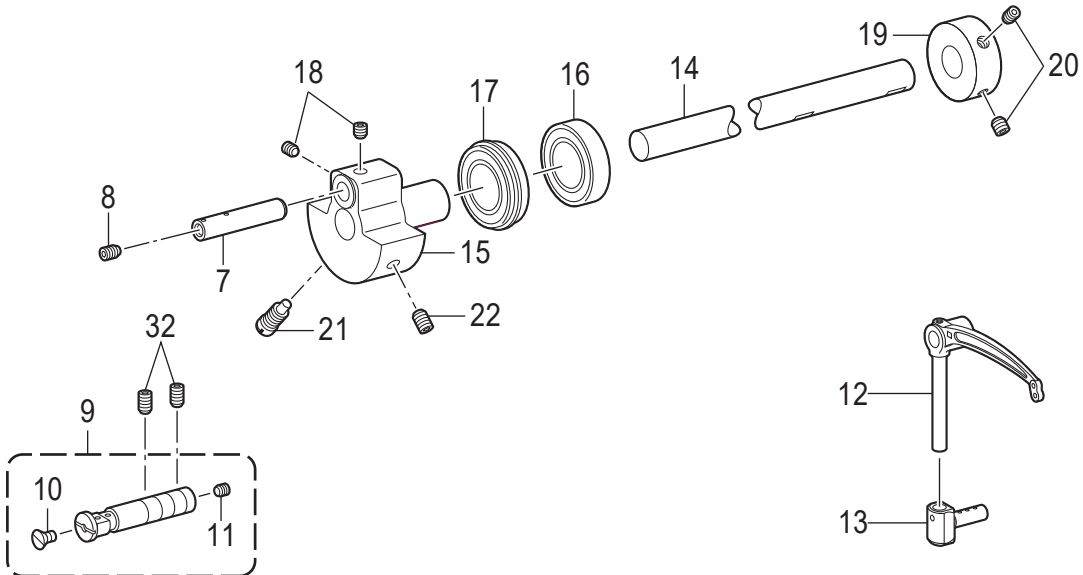



B. 上軸関係 / Upper shaft mechanism

REF.NO	CODE	Q'TY	品名	NAME OF PARTS	RM
			<-□0□用>	<For -□0□>	
1	SA6166001	1	ハリボウクランクジク	CRANKSHAFT	
2	117006001	1	クミヒモ	WICK, L=60	
3	113014000	1	クミヒモフタ	PUSHER	
4	SA2861101	1	テンビンササエジクソウクミ	THREAD TAKE-UP S-SHAFT UNIT	
5	SA2935201	1	テンビンS3-Lクミ	THREAD TAKE-UP LEVER ASSY S3-L	
6	S13160001	1	テンビンスベリコ2クミ	T-TAKE-UP SLIDE BLOCK ASSY, 2	
			<-T3F用>	<For -T3F>	
7	SA4112101	1	テンビנקランクジクP	THREAD TAKE-UP CRANK SHAFT P	
8	012500536	1	アナヒラ5X5	SET SCREW SOCKET (FT) M5X5	
9	SA2464101	1	テンビンササエジククミ	THREAD TAKE-UP S-SHAFT ASSY	
10	SA2958001	1	サラネジ5X6	SCREW FLAT M5X6	
11	012500536	1	アナヒラ5X5	SET SCREW SOCKET (FT) M5X5	
12	SA4115101	1	テンビンS3P	THREAD TAKE-UP LEVER S3 P	
13	SA4129101	1	テンビンスベリコクミ	THREAD TAKE-UP SLIDE B-ASSY	
14	SA2452101	1	ウワジクDD	UPPER SHAFT, DD	
15	SA4089001	1	テンビנקランク	THREAD TAKE-UP CRANK	
16	SB1485001	1	タマジクウケ6004ZZ	BALL BEARING 6004ZZ	
17	SB1535001	1	タマジクウケ6004ZZNR	BALL BEARING 6004ZZNR	
18	S25260001	2	アナヒラ6X5ホソメ	SET SCREW SOCKET (FT) M6X5	
19	SA1120001	1	イトマキクドウリン	BOBBIN WINDER DRIVING WHEEL	
20	S23651001	2	アナヒラ6X6ホソメ	SET SCREW SOCKET (FT) M6X6	
21	S25235001	1	シメネジ8	SCREW M8	
22	S25236001	1	アナヒラ6X10ホソメ	SET SCREW SOCKET (FT) M6X10	
23	SA2460101	1	ツギテソウクミ	PRESSER ADJUSTING UNIT	
24	SB1536001	1	タマジクウケ6204ZZNR	BALL BEARING 6204ZZNR	
25	S23651001	4	アナヒラ6X6ホソメ	SET SCREW SOCKET (FT) M6X6	
26	SA2461001	1	タイミングプーリU DD	TIMING PULLEY, U DD	
27	S38713100	1	ファン	FAN	
28	SA2404001	3	ナベザクミ4X35DB	SCREW, PAN (S WASHER) M4X35	
31	SA2463001	1	タイミングベルト	TIMING BELT	
32	012061036	2	アナヒラ6X10	SET SCREW SOCKET (FT) M6X10	
33	SA2469101	1	テンビンカバー	THREAD TAKE-UP LEVER COVER	
34	062500816	2	ナベコ5X8	SCREW PAN M5X8	
35	SA4537001	1	ダストカバー	DUST COVER	
36	SA3058101	1	シヤヘイバン	SHELTER PLATE	
37	SA3065001	1	フェルト	FELT	
38	SA3059101	1	シヤヘイバンオサエ	HOLDER, SHELTER PLATE	
39	062500816	1	ナベコ5X8	SCREW PAN M5X8	
40	SA2462001	1	プーリUフランジ	PULLEY U FLANGE	

### C. 針棒揺動関係 / Needle bar rocking mechanism

< 微量給油仕様 -[ ]0[ ]用 / For -[ ]0[ ] Minimum lubrication type >

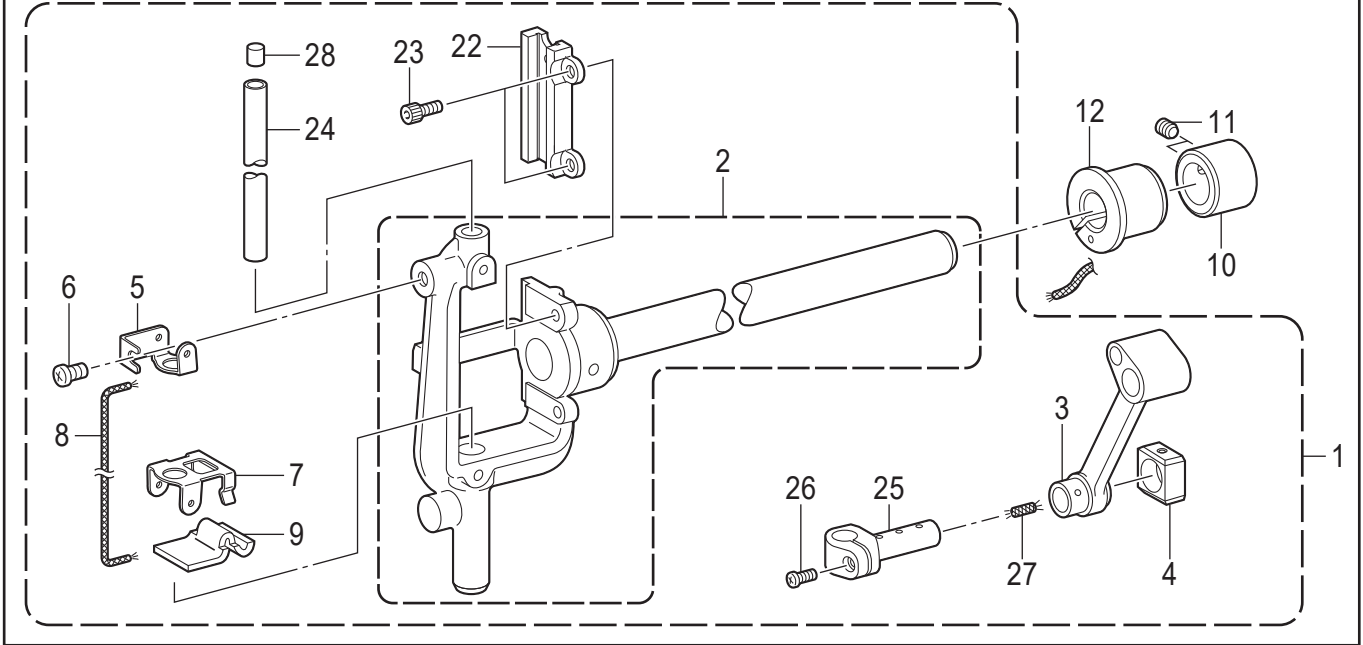

< セミドライ仕様 -T3F 用 / For -T3F Semi dry type >

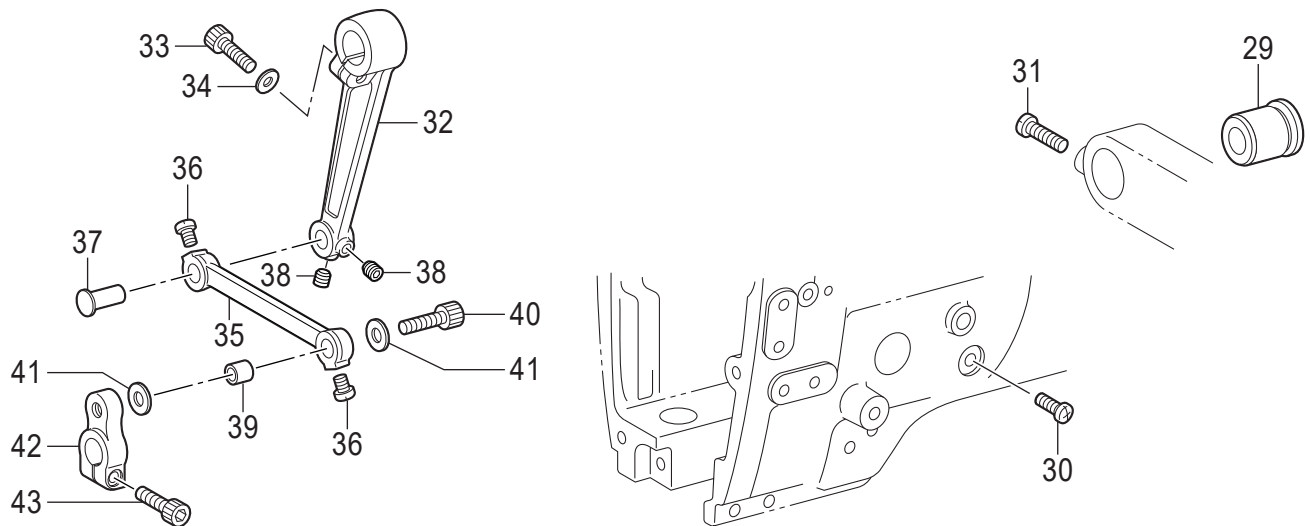
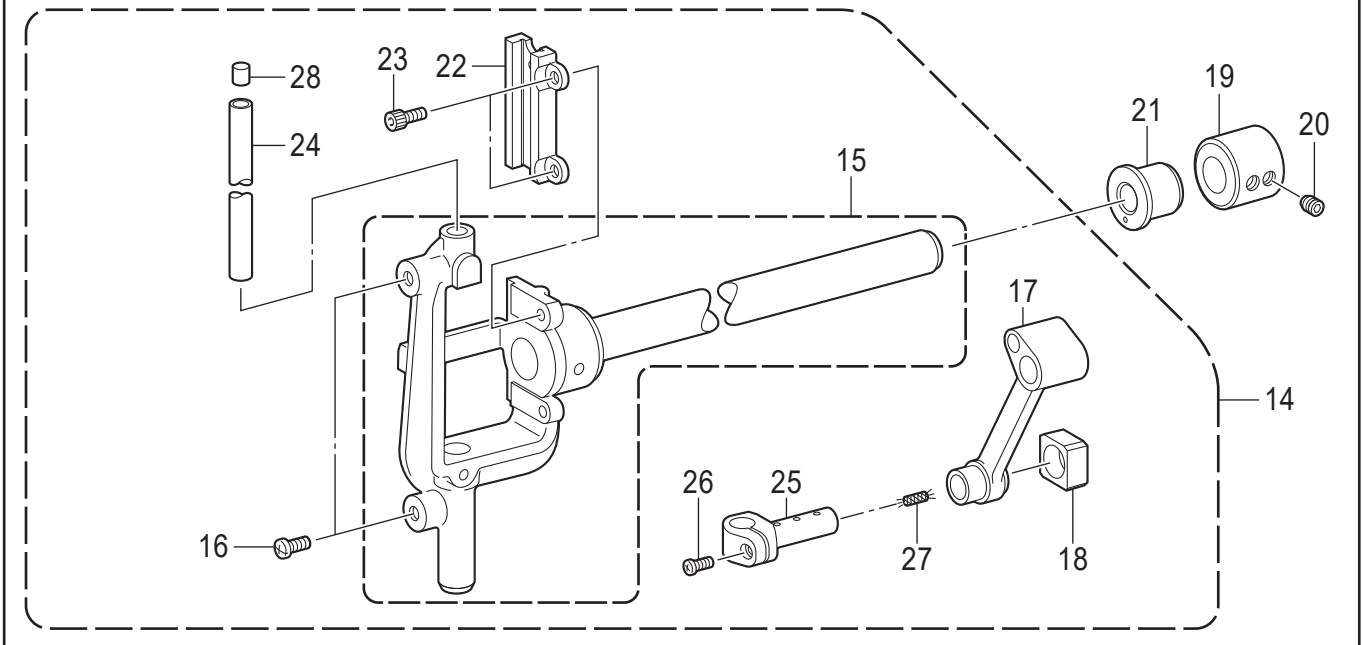

C. 針棒揺動関係 / Needle bar rocking mechanism

REF.NO	CODE	Q'TY	品名	NAME OF PARTS	RM
			<-□0□用>	<For -□0□>	
1	SA8893101	1	ハリボウヨウドウジククミ	NEEDLE BAR ROCKER SHAFT ASSY	
2	SB1423001	1	ハリボウダイクミ	NEEDLE BAR BASE ASSY	
3	SA3711101	1	ハリボウクランクロッド	CRANK ROD, N-BAR	
4	SA3712001	1	カクコマ	SLIDE BLOCK	
5	SA4007001	1	フェルトオサエU	FELT SUPPORT, U	
6	062500616	1	ナベコ5X6	SCREW PAN M5X6	
7	SA3848001	1	フェルトオサエD	FELT SUPPORT, D	
8	S07465000	1	クミヒモ	WICK L=200	
9	SA3852001	1	フェルト	FELT	
10	SA2485001	1	セットカラー	SET SCREW COLLAR	
11	S25260001	2	アナヒラ6X5ホソメ	SET SCREW SOCKET (FT) M6X5	
12	SA5332001	1	ヨウドウジクメタルL	BUSH L	
			<-T3F用>	<For -T3F>	
14	SA4093301	1	ハリボウヨウドウジククミ	NEEDLE BAR ROCKER SHAFT ASSY	
15	SB1429001	1	ハリボウダイクミ	NEEDLE BAR BASE ASSY	
16	062500816	2	ナベコ5X8	SCREW PAN M5X8	
17	SA4094001	1	ハリボウクランクロッド	CRANK ROD, N-BAR	
18	SA2481001	1	カクコマ	SLIDE BLOCK	
19	SA2485001	1	セットカラー	SET SCREW COLLAR	
20	S25260001	2	アナヒラ6X5ホソメ	SET SCREW SOCKET (FT) M6X5	
21	SA4095001	1	ヨウドウジクメタルL	BUSH, L	
22	SB1425001	1	カクコマスライダ	SLIDE BLOCK SLIDER	
23	018401036	2	アナボルト4X10	BOLT SOCKET M4X10	
24	SA2475101	1	ハリボウ	NEEDLE BAR	
25	SA3710001	1	ハリボウダキ	NEEDLE BAR CLAMP	
26	062350816	1	ナベコ35X8	SCREW PAN M3.5X8	
27	112728001	1	クミヒモ	WICK, L=50	
28	148394000	1	ハリボウセン	CAP N-BAR	
29	SA2486101	1	ヨウドウジクメタルR	BUSH, R	
30	062500816	1	ナベコ5X8	SCREW PAN M5X8	
31	062061616	1	ナベコ6X16	SCREW PAN M6X16	
32	SA2489001	1	ハリボウヨウドウレバー	NEEDLE BAR ROCKER LEVER	
33	018062032	1	アナボルト6X20	BOLT SOCKET M6X20	
34	118735002	1	ザガネ	WASHER	
35	SA2490101	1	ハリボウヨウドウリンク	ROCKER LINK N-BAR	
36	S23460001	2	ナベコ6X5	SCREW PAN M6X5	
37	SB4197001	1	ヨウドウリンクジク	LINK SHAFT N-BAR ROCKER	
38	012060636	2	アナヒラ6X6	SET SCREW SOCKET (FT) M6X6	
39	SB4198001	1	ヨウドウリンクカラー	ZIGZAG LINK BUSH	
40	018062532	1	アナボルト6X25	BOLT SOCKET M6X25	
41	SA2493001	2	ザガネ	WASHER, PLAIN	
42	SA2494001	1	ハリボウヨウドウウデ	NEEDLE BAR ROCK ARM	
43	018062032	1	アナボルト6X20	BOLT SOCKET M6X20	

D. 押え関係 / Presser foot mechanism

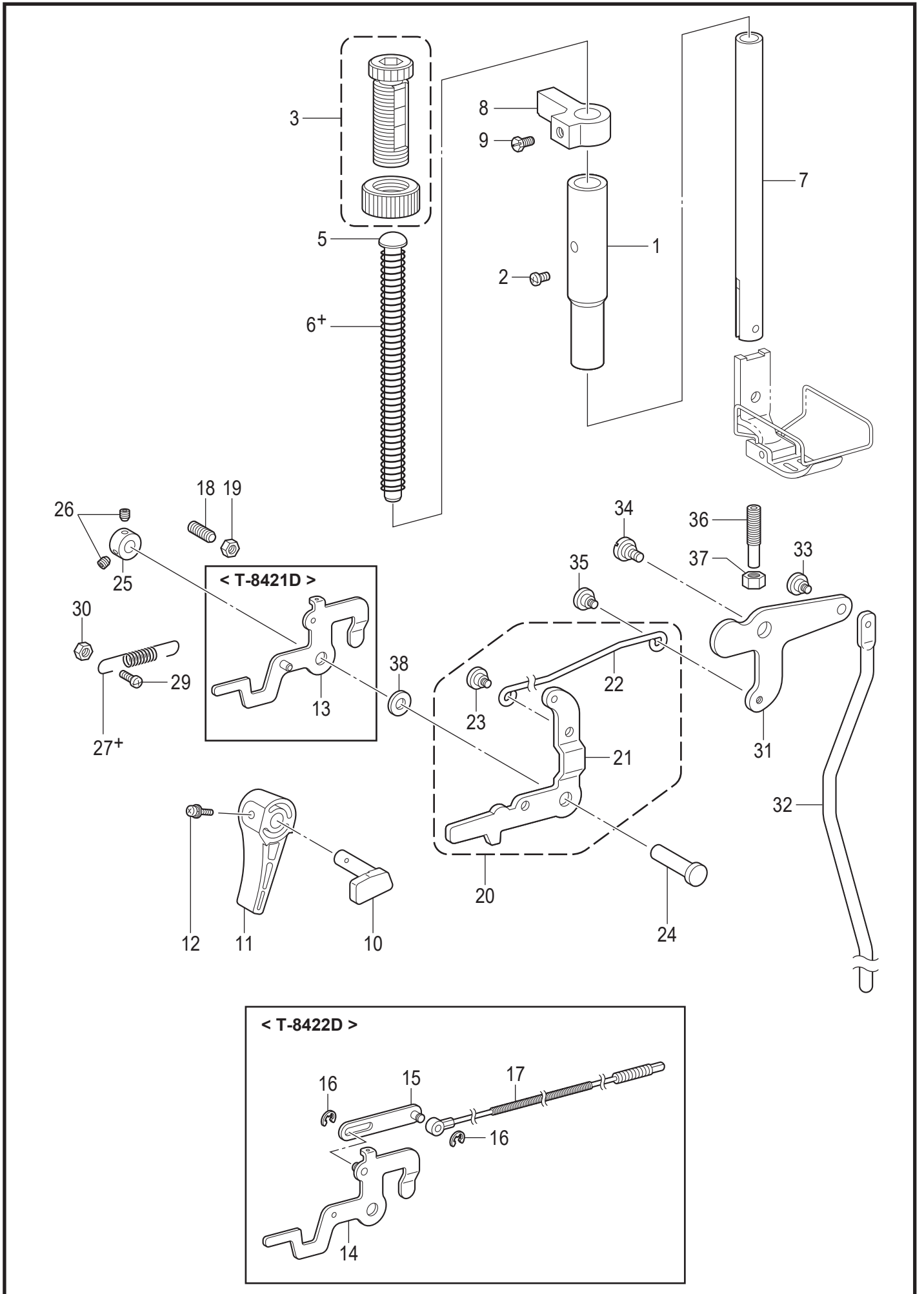

## D. 押え関係 / Presser foot mechanism

REF.NO	CODE	Q'TY	品名	NAME OF PARTS	RM
1	SA2495001	1	オサエボウメタル	PRESSER BAR BUSH	
2	062500816	1	ナベコ5X8	SCREW PAN M5X8	
3	SB2265002	1	オサエチョウセツネジクミ	PRESSER ADJUSTING SCREW ASSY	
5	SA7607101	1	オサエバネアンナイ	SPRING GUIDE	
6+	S07346101	1	<-□03, -□05, -S07用> オサエバネ	<For -□03, -□05, -S07> PRESSER BAR SPRING, -5	
6+	S16196001	1	<-T□F用> オサエバネ	<For -T□F> PRESSER BAR SPRING, F	
7	SB4195001	1	オサエボウ	PRESSER BAR	
8	SA2498001	1	オサエボウダキ	GUIDE BRACKET, P-BAR	
9	S25289001	1	ボルト6	BOLT (CP) M6X10	
10	SA2499001	1	オサエアゲクランク	PRESSER BAR LIFTING CRANK	
11	S31006002	1	オサエアゲテコ	LIFTING LEVER	
12	S39051001	1	ナベザクミ35X12	SCREW, PAN (S/P W) M3.5X12	
13	S07353001	1	<T-8421D用> イトユルメイタクミ	<For T-8421D> TENSION RELEASE PLATE ASSY	
14	S07351001	1	<T-8422D用> イトユルメイタクミ	<For T-8422D> TENSION RELEASE PLATE ASSY	
15	S07529001	1	イトユルメレンカンクミ	T-RELEASE CONNECTING ROD ASSY	
16	048030342	2	トメワE3	RETAINING RING E3	
17	SA2677201	1	イトユルメワイヤー	TENSION RELEASE WIRE	
18	012061832	1	アナヒラ6X18	SET SCREW, SOCKET (FT) M6X18	
19	021060306	1	3シュナット6	NUT 3 M6	
20	SA2500001	1	ヒザアゲレンカンクミ	KNEE LIFTER C-ROD ASSY	
21	SA2501001	1	オサエアゲレバー	PRESSER BAR LIFTING LEVER	
22	SA2502001	1	ヒザアゲレンカン	KNEE LIFTER CONNECTING ROD	
23	SA1179001	1	ダンネジ5	SHOULDER SCREW M5	
24	S07349001	1	オサエアゲレバー-ジク	P-BAR LIFTING LEVER SHAFT	
25	SA2504001	1	セツトカラ-	SET SCREW COLLAR	
26	012500536	2	アナヒラ5X5	SET SCREW SOCKET (FT) M5X5	
27+	S07355051	1	<T-8421D用> オサエアゲレバー-バネ	<For T-8421D> SPRING, EXTENSION	
27+	S07355051	2	<T-8422D用> オサエアゲレバー-バネ	<For T-8422D> SPRING, EXTENSION	
29	062501216	1	ナベコ5X12	SCREW PAN M5X12	
30	021500106	1	1シュナット5	NUT 1 M5	
31	SA2506001	1	ヒザアゲレバー	KNEE LIFTER LEVER	
32	SA2507001	1	ヒザアゲボウ	KNEE LIFTER BAR	
33	SA1179001	1	ダンネジ5	SHOULDER SCREW M5	
34	SA2165001	1	ダンネジ6	SHOULDER SCREW, M6	
35	SA1179001	1	ダンネジ5	SHOULDER SCREW M5	
36	SA4149101	1	チヨウセツネジ6	ADJUSTING SCREW 6	
37	021060306	1	3シュナット6	NUT 3 M6	
38	S07350001	1	ザガネ	WASHER PLAIN	

E. 送り関係 / Feed mechanism

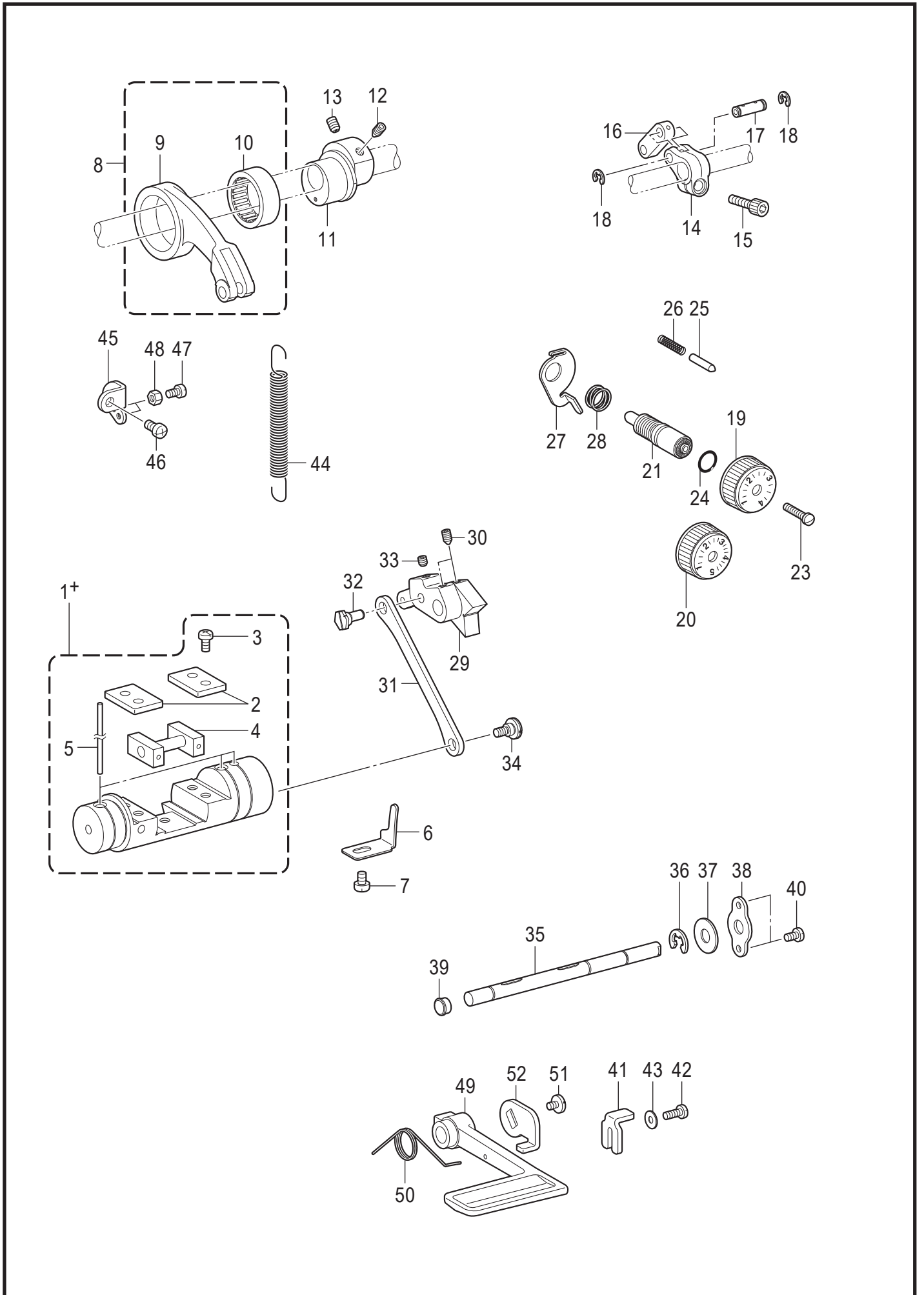

## E. 送り関係 / Feed mechanism

REF.NO	CODE	Q'TY	品名	NAME OF PARTS	RM
1+	SA3062001	1	<-□03,-T□F用> キリカエキ11クミ	<For -□03,-T□F> FEED REGULATOR ASSY, 11	
1+	SA2509001	1	<-□05,-S07用> キリカエキクミ	<For -□05,-S07> FEED REGULATOR ASSY	
2	SA2511001	2	カクコマアンナイイタ	GUIDE PLATE	
3	062501016	4	ナベコ5X10	SCREW PAN M5X10	
4	SA2512001	1	キリカエキカクコマクミ	SLIDE BLOCK ASSY	
5	SA2515001	3	フェルト	FELT	
6	SA2516001	1	キリカエキトメ	STOPPER	
7	062060816	1	ナベコ6X8	SCREW PAN M6X8	
8	143611201	1	スイヘイオクリレンカンクミ	F-ROCKER CONNECTING ROD ASSY	
9	143612100	1	スイヘイオクリレンカン	FEED ROCKER CONNECTING ROD	
10	118954000	1	ニードルベアリング	NEEDLE BEARING	
11	SA2518001	1	スイヘイヘンシンリン5	LEVEL FEED ECCENTRIC WHEEL 5	
12	SA2585001	1	アナトガリ6X10ホソメ	SET SCREW, SOCKET (FT) M6	
13	S25236001	1	アナヒラ6X10ホソメ	SET SCREW SOCKET (FT) M6X10	
14	SA2521001	1	スイヘイオクリウデ5	FEED ROCKER ARM 5	
15	018062032	1	アナボルト6X20	BOLT SOCKET M6X20	
16	143613051	1	スイヘイオクリウデリンク	LINK	
17	143616001	1	スイヘイオクリウデジク	SHAFT	
18	048060342	2	トメワE6	RETAINING RING E6	
19	SB9865001	1	<-□03,-T□F用> オクリメモリダイヤル	<For -□03,-T□F> STITCH LENGTH DIAL 4	
20	SB9867001	1	<-□05,-S07用> オクリメモリダイヤル	<For -□05,-S07> STITCH LENGTH DIAL 5	
21	SA3056101	1	オクリチヨウセツネジ	FEED REGULATING STUD	
23	SA4494001	1	シメネジ4.76	SCREW SM4.76	
24	108549001	1	Oリング	O RING	
25	S50098201	1	メモリイチギメピン	POSITIONING PIN	
26	100328001	1	メモリイチキメピンバネ	NOTCH SPRING	
27	SA2523001	1	ダイヤルロツクレバー	DIAL LOCK LEVER	
28	S39830101	1	ダイヤルロツクレバーバネ	SPRING	
29	SA2525001	1	オクリチヨウセツキ5	FEED REGULATOR 5	
30	016061031	2	アナトガリ6X10	SET SCREW SOCKET (CN) M6X10	
31	SA2526001	1	キリカエキレンカン	CONNECTING ROD	
32	SB4125001	1	ヘンシンジク	ECCENTRIC SHAFT	
33	012060636	1	アナヒラ6X6	SET SCREW SOCKET (FT) M6X6	
34	SB7507001	1	ダンネジ6	SHOULDER SCREW M6	
35	SA2529101	1	カエシヌイレバージクTR	SHAFT R-LEVER TR	
36	048080342	1	トメワE8	RETAINING RING E8	
37	025100132	1	ヒラザガネショウ10	WASHER PLAIN S 10	
38	SA2530001	1	カンザ	SPACER	
39	104821001	1	ゴムセン10.5	RUBBER CAP, 10.5	
40	062500816	2	ナベコ5X8	SCREW PAN M5X8	
41	SA2532001	1	ハンドルストツパ	STOPPER	
42	062501216	1	ナベコ5X12	SCREW PAN M5X12	
43	SB3849001	1	ヒラザガネチュウ5	WASHER_PLAIN_M_5	
44	S07376001	1	キリカエキバネ	FEED REGULATOR SPRING	
45	SA2533001	1	バネカケ	SPRING HOOK	
46	062060816	1	ナベコ6X8	SCREW PAN M6X8	
47	062501216	1	ナベコ5X12	SCREW PAN M5X12	
48	021500106	1	1シュナット5	NUT 1 M5	
49	S07374102	1	カエシヌイレバー	REVERSE STITCHING LEVER	
50	SA2531001	1	カエシヌイレバーオサエバネ	SPRING	
51	SA6592001	1	シメネジM5	SCREW M5	
52	SA2541001	1	カエシヌイレバーイタ	REVERSE STITCHING LEVER PLATE	

F. 逆転関係 / Quick reverse mechanism

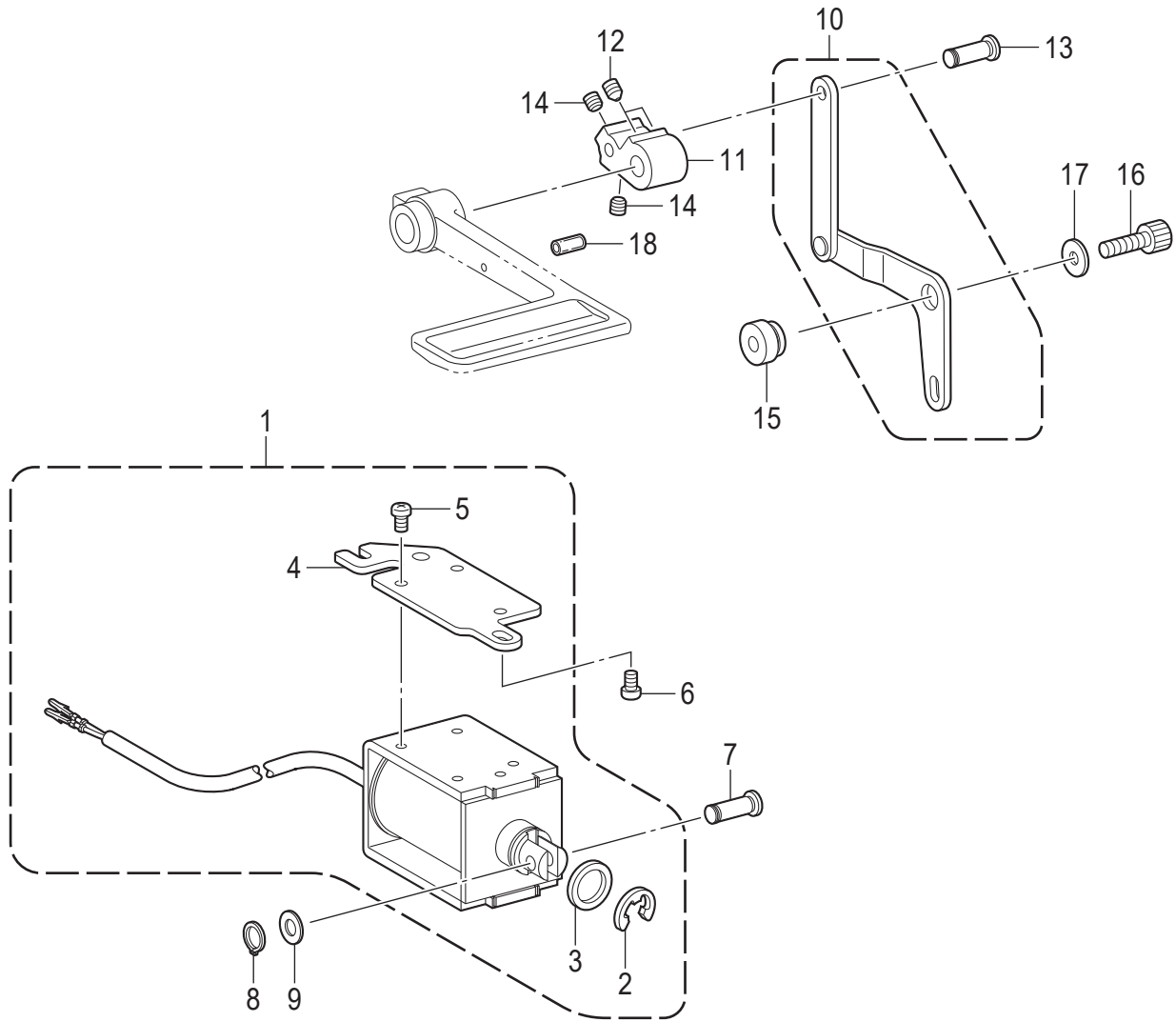



## F. 逆転関係 / Quick reverse mechanism

REF.NO	CODE	Q'TY	品名	NAME OF PARTS	RM
1	SB9911001	1	ギャクテンソレノイドオオクミ	QUICK REVERSE SOLENOID UNIT	
2	154730001	1	トメワE15	RETAINING RING E15	
3	154731000	1	ゴムストツパー	RUBBER STOPPER	
4	SA2535101	1	ソレノイドドダイ	SOLENOID BRACKET	
5	062500812	3	ナベコ5X8	SCREW PAN M5X8	
6	062061016	2	ナベコ6X10	SCREW PAN M6X10	
7	SA2992001	1	レンケツピン	PIN	
8	048060142	1	トメワジクヨウC6	RETAINING RING EXTERNAL C6	
9	153138001	1	ザガネ	WASHER, PLAIN 6.5	
10	SA2536001	1	ソレノイドレバークミ	SOLENOID LEVER ASSY	
11	SA2540001	1	ギャクテンレバ-	QUICK REVERSE LEVER	
12	016061031	2	アナトガリ6X10	SET SCREW SOCKET (CN) M6X10	
13	SA2992001	1	レンケツピン	PIN	
14	012060636	2	アナヒラ6X6	SET SCREW SOCKET (FT) M6X6	
15	SA2539001	1	ソレノイドレバ-ジク	SOLENOID LEVER SHAFT	
16	018062032	1	アナボルト6X20	BOLT SOCKET M6X20	
17	149095001	1	ザガネ	WASHER, PLAIN 6	
18	153132000	1	ナイロンチューブ	NYLON TUBE L=13.5	

G. 送り軸関係 / Feed shaft mechanism

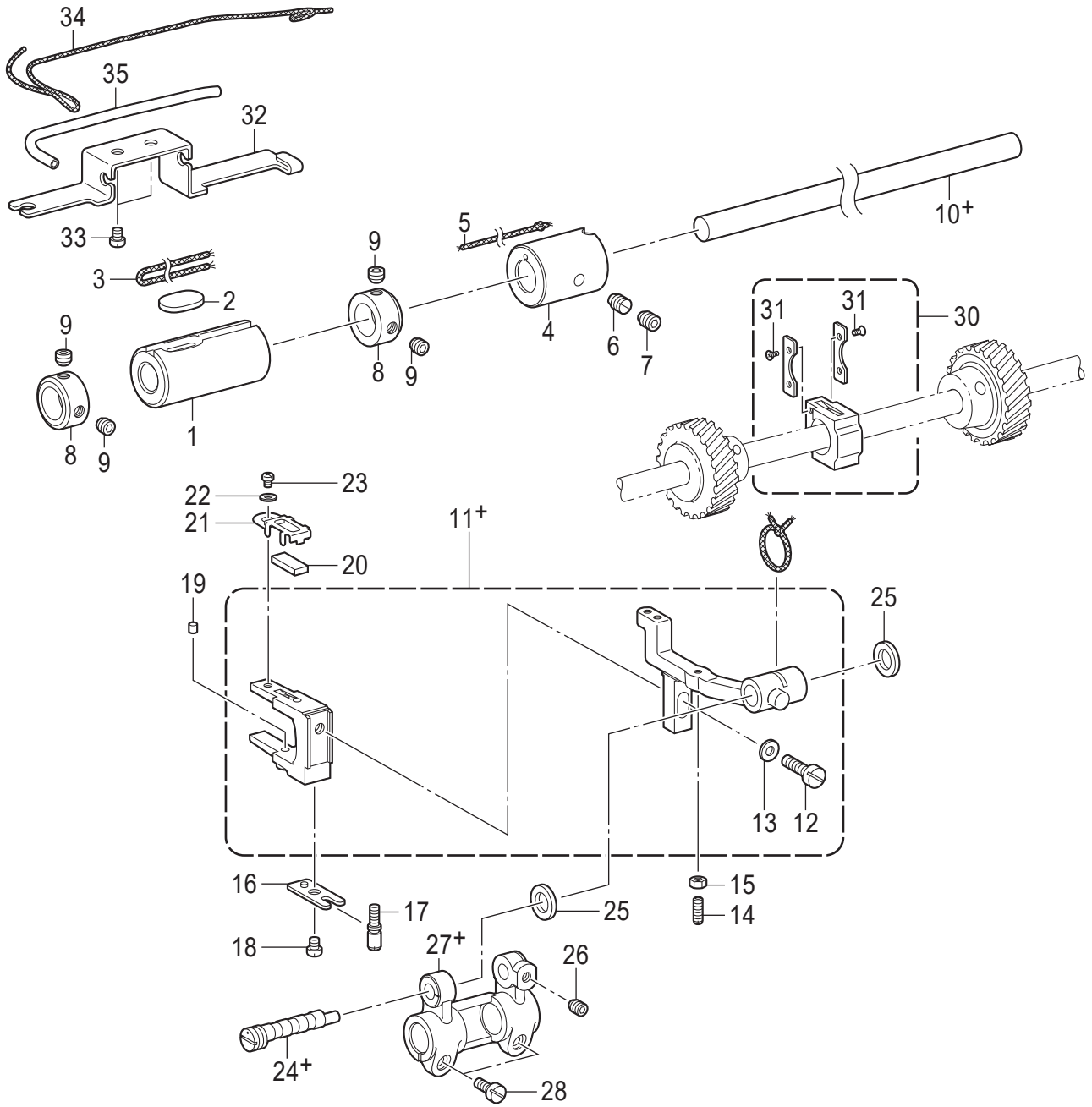

< -S0□ 用 / For -S0□ >

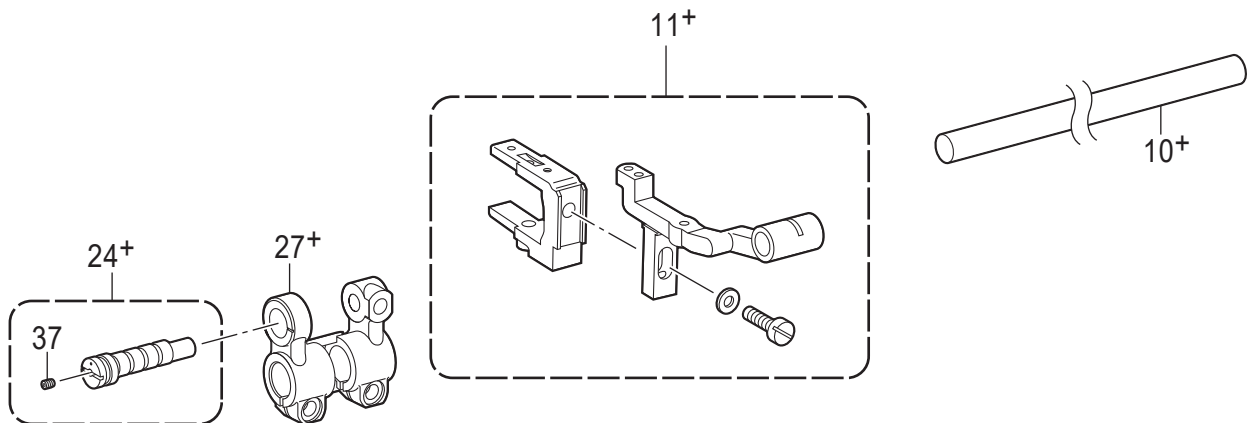

## G. 送り軸関係 / Feed shaft mechanism

REF.NO	CODE	Q'TY	品名	NAME OF PARTS	RM
1	SA3855001	1	オクリジクメタルL	BUSH, L: F-ROCKER SHAFT	
2	SA3965001	1	フェルト	FELT	
3	SA4028001	1	クミヒモ4X4 L=220	WICK, 4X4 L=220	
4	SA2543001	1	オクリジクメタルR	FEED ROCKER SHAFT BUSH, R	
5	108802001	1	クミヒモ4X4	WICK, 4X4 L=250	
6	SA2544001	1	トメネジM6	SET SCREW M6	
7	012060636	1	アナヒラ6X6	SET SCREW SOCKET (FT) M6X6	
8	SA2546001	2	セットカラー	SET SCREW COLLAR	
9	S23651001	4	アナヒラ6X6ホソメ	SET SCREW SOCKET (FT) M6X6	
10+	SA3840001	1	スイヘイオクリジク	FEED ROCKER SHAFT	
			<T-8421D用>	<For T-8421D>	
11+	SA6152101	1	オクリダイSTフタマタクミ	FEED BAR ST FORK ASSY	
			<T-8422D用>	<For T-8422D>	
11+	SA6150101	1	オクリダイTRフタマタクミ	FEED BAR TR FORK ASSY	
12	SA2927001	1	シメネジM6X14	SCREW, M6X14	
13	025060132	1	ヒラザガネシヨウ6	WASHER PLAIN S 6	
14	SA2566001	1	トメネジ3.5	SET SCREW, M3.5	
15	021350106	1	1シュナット35	NUT 1 M3.5	
16	SA2553001	1	フタマタプレート	FORKED PLATE	
17	SA2554001	1	タカサチヨウセツネジ	ADJUSTING SCREW	
18	062400616	1	ナベコ4X6	SCREW PAN M4X6	
19	SA3990001	1	フェルト	FELT	
20	SA3887001	1	フェルト	FELT	
21	SA3888001	1	フェルトオサエ	FELT HOLDER	
22	025030132	1	ヒラザガネシヨウ3	WASHER PLAIN S 3	
23	062300416	1	ナベコ3X4	SCREW PAN M3X4	
24+	SB4126001	1	オクリダイトリツケジク	FEED BAR SHAFT	
25	SA2551001	2	スラストリング	THRUST RING	
26	012060636	1	アナヒラ6X6	SET SCREW SOCKET (FT) M6X6	
27+	SA2555001	1	スイヘイオクリダイウデ	FEED ROCKER BASE ARM	
28	SA2928001	2	シメネジM5X12	SCREW, M5X12	
30	SA2806101	1	オクリダイカクコマクミ	FEED BAR SLIDE BLOCK ASSY	
31	SA6308001	4	0サラコ3シュ2X4	SCREW FLAT #0 M2X4	
32	SA4009001	1	クミヒモササエ	WICK SUPPORT	
33	062400616	2	ナベコ4X6	SCREW PAN M4X6	
34	SA2724001	1	クミヒモ	WICK, L=400	
35	SA4011001	1	ビニルチューブ L=100	OIL TUBE L=100	
			<-S0□用>	<For -S0□>	
10+	SC0694001	1	スイヘイオクリジク	FEED ROCKER SHAFT	
11+	SC0697001	1	オクリダイSTRフタマタクミ	FEED BAR TR FORK ASSY	
24+	SC0733001	1	オクリダイトリツケジククミ	FEED LIFTING R-BAR SHAFT ASSY	
27+	SC0732001	1	スイヘイオクリダイウデ	FEED ROCKER BASE ARM	
37	014300432	1	アナクボミ3X4	SET SCREW SOCKET (CP) M3X4	

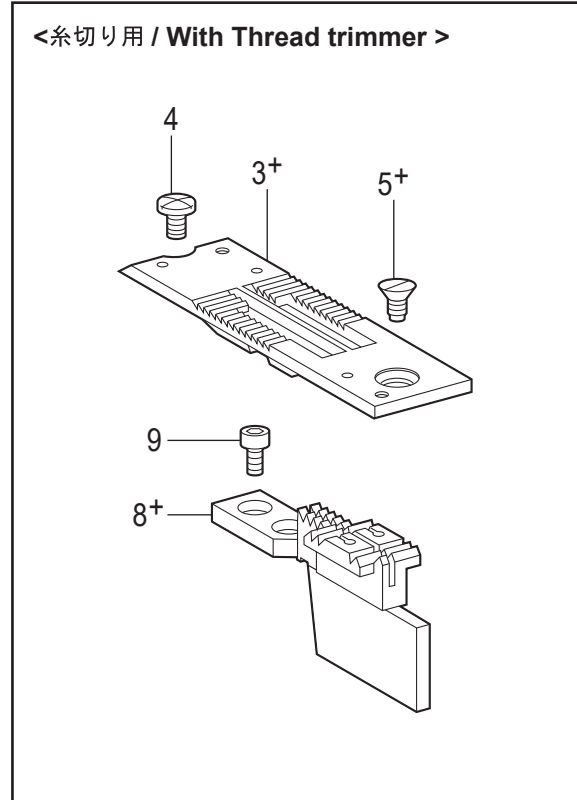
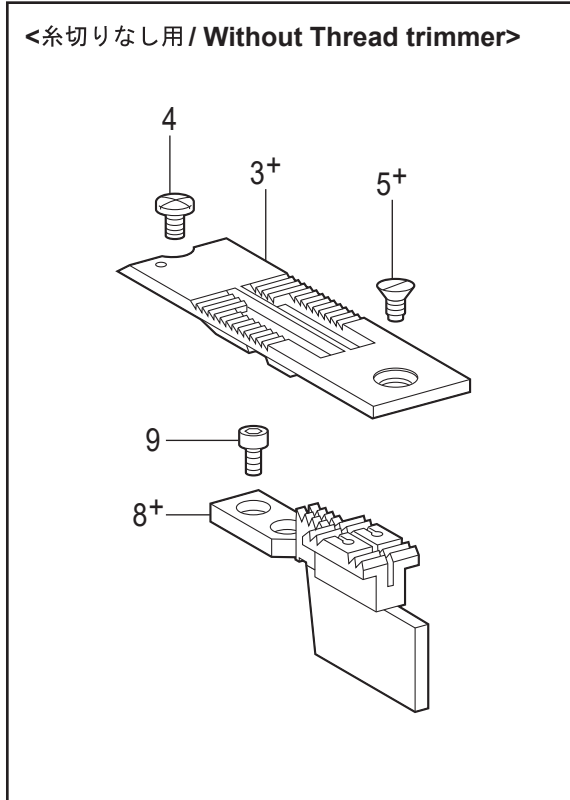
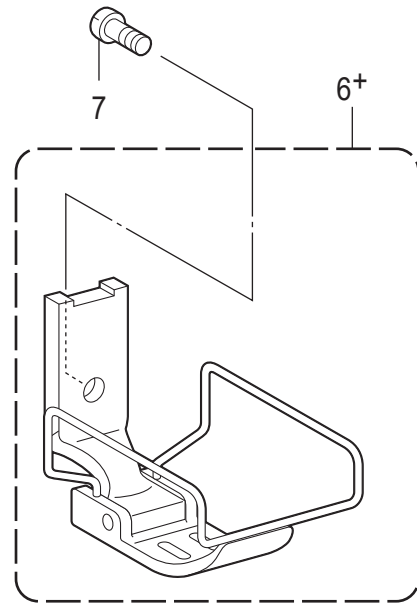
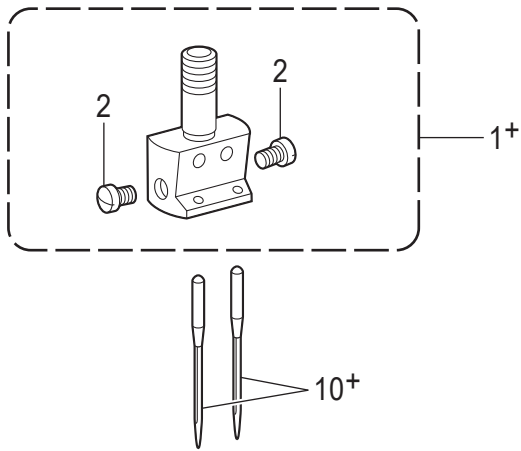

H. ゲージ関係 / Gauge parts

REF.NO	CODE	Q'TY	品名	NAME OF PARTS	RM
1+	* P.65-72	1	ハリダキクミ	NEEDLE CLAMP ASSY	
2	116323001	2	シメネジ3.57	SCREW, SM3.57	
3+	* P.65-72	1	ハリイタ	NEEDLE PLATE	
4	S11244001	1	シメネジ4.37	SCREW, SM4.37	
			<-□03, -□05,-S07用>	<For -□03, -□05,-S07>	
5+	SC0568001	1	サラネジ4.37	SCREW FLAT SM4.37-40X8	
			<-T□F用>	<For -T□F>	
5+	117160001	1	サラネジ4.37	SCREW, FLAT SM4.37	
6+	* P.65-72	1	オサエクミ	PRESSER FOOT ASSY	
7	113050001	1	シメネジ3.57	SCREW, SM3.57	
8+	* P.65-72	1	オクリバ	FEED DOG	
9	S07494001	2	シメネジ3.18	SCREW, W/SOCKET SM3.18X7	
			<-□03用>	<For -□03>	
10+			マシンハリ DPX5…(#14)	NEEDLE DPX5…(#14)	
			<-□05,-S07用>	<For -□05,-S07>	
10+			マシンハリ DPX5…(#22)	NEEDLE DPX5…(#22)	
			<-T□F用>	<For -T□F>	
10+			マシンハリ DPX5…(#11)	NEEDLE DPX5…(#11)	

J1. かま関係 (T-8421D) / Rotary hook mechanism (T-8421D)

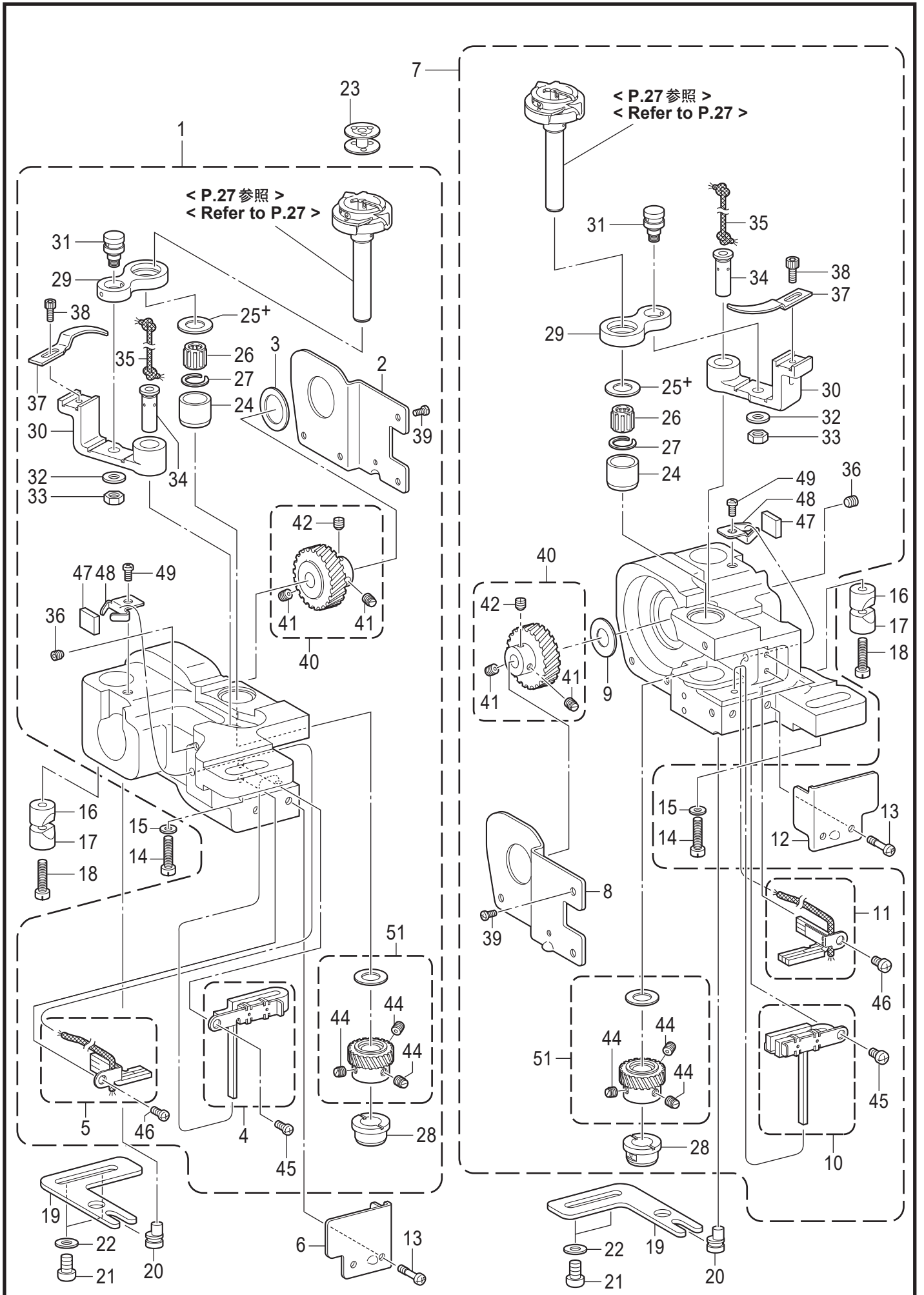

J1. かま関係 (T-8421D) / Rotary hook mechanism (T-8421D)

REF.NO	CODE	Q'TY	品名	NAME OF PARTS	RM
			<かま土台(L)用>	<For Rotary hook base (L)>	
1	SB4823201	1	カマドダイ842ST-LクミC	R-HOOK BASE ASSY 842ST(L) C	
2	SA2562201	1	カマドダイカバー-L	ROTARY HOOK BASE COVER L	
3	SA3054001	1	スラストザガネL	THRUST WASHER, L	
4	SA6424201	1	フェルトULクミ	FELT UL ASSY	
5	SA4044001	1	フェルトDLクミ	FELT DL ASSY	
6	SA6462001	1	カマドダイカバー-FL	ROTARY HOOK BASE COVER FL	
			<かま土台(R)用>	<For Rotary hook base (R)>	
7	SB4824201	1	カマドダイ842ST-RクミC	R-HOOK BASE ASSY 842ST(R) C	
8	SA2563301	1	カマドダイカバー-R	ROTARY HOOK BASE COVER R	
9	SA2579001	1	スラストザガネ	SPACER	
10	SA6425201	1	フェルトURクミ	FELT UR ASSY	
11	SA4045001	1	フェルトDRクミ	FELT DR ASSY	
12	SA6463001	1	カマドダイカバー-FR	ROTARY HOOK BASE COVER FR	
13	SA6417001	4	シメネジM4X12	SCREW M4X12	
14	SA2556001	2	シメネジM6X25	SCREW, M6X25	
15	115947101	2	ザガネ	WASHER PLAIN 6.35	
16	SA2722001	2	ピンチスリーブA	PINCH SLEEVE A	
17	SA2565001	2	ピンチスリーブB	PINCH SLEEVE B	
18	SA2556001	2	シメネジM6X25	SCREW, M6X25	
19	SA2567001	2	ハリスキチヨウセツイタ	NEEDLE UPPER ADJUSTING PLATE	
20	SA2568001	2	ハリスキチヨウセツジク	NEEDLE UPPER POSITIONING SHAFT	
21	062061016	4	ナベコ6X10	SCREW PAN M6X10	
22	025060136	4	ヒラザガネショウ6	WASHER PLAIN S 6	
23	S01928151	2	ボビン	BOBBIN	
24	SA4029001	2	カマジクメタルU	ROTARY HOOK SHAFT BUSH	
25+	S09260001	2	スラストリングA <t=1.2>	THRUST RING A: 1.2MM <t=1.2>	
25+	SA4038001	2	スラストリング <t=1.0>	THRUST RING <t=1.0>	
25+	S09261001	2	スラストリングB <t=1.4>	THRUST RING, B: 1.4MM <t=1.4>	
25+	SA4444001	2	スラストリング0.8 <t=0.8>	THRUST RING 0.8MM <t=0.8>	
26	S07420000	2	ニードルベアリング	NEEDLE BEARING	
27	S07419001	2	ストツプリング	RETAINING RING	
28	SA6474001	2	カマジクメタルD	ROTARY HOOK SHAFT BUSH	
29	SB4193001	2	オープナーリンク	OPENER LINK	
30	SA3859101	2	オープナーレバー	OPENER LEVER	
31	SA2560001	2	オープナーリンクジク	SHAFT O-LINK	
32	SB2330001	2	ヒラザガネショウ4.76	WASHER PLAIN S SM4.76	
33	021500316	2	3シュナット5	NUT 3 M5	
34	SA3889101	2	オープナーレバージク	O-LEVER SHAFT	
35	SA4026001	2	クミヒモ4X4 L=100	WICK, 4X4 L=100	
36	012501031	2	アナヒラ5X10	SET SCREW SOCKET (FT) M5X10	
37	S38212001	2	オープナー	OPENER	
38	154965001	2	アナボルト3.57X8	BOLT, SOCKET SM3.57X8	
39	062300612	8	ナベコ3X6	SCREW PAN M3X6	
40	SA2572201	2	スパイラルギヤ ネジツキ	SPIRAL GEAR SCREW ASSY	
41	SA2574001	4	トメネジM6ホソメ	SET SCREW, (FT) M6	
42	SA2575101	2	トメネジM6ホソメ	SET SCREW (FT) M6	
44	SA2574001	6	トメネジM6ホソメ	SET SCREW, (FT) M6	
45	062400616	2	ナベコ4X6	SCREW PAN M4X6	
46	062400616	2	ナベコ4X6	SCREW PAN M4X6	
47	SA4012001	2	フェルト	FELT	
48	SA3894001	2	フェルトオサエ	FELT SUPPORT	
49	062400616	2	ナベコ4X6	SCREW PAN M4X6	
51	SA6307201	2	ピニオンセット	PINION GEAR SET	

J2. かま関係 (T-8422D-40[]) / Rotary hook mechanism (T-8422D-40[])

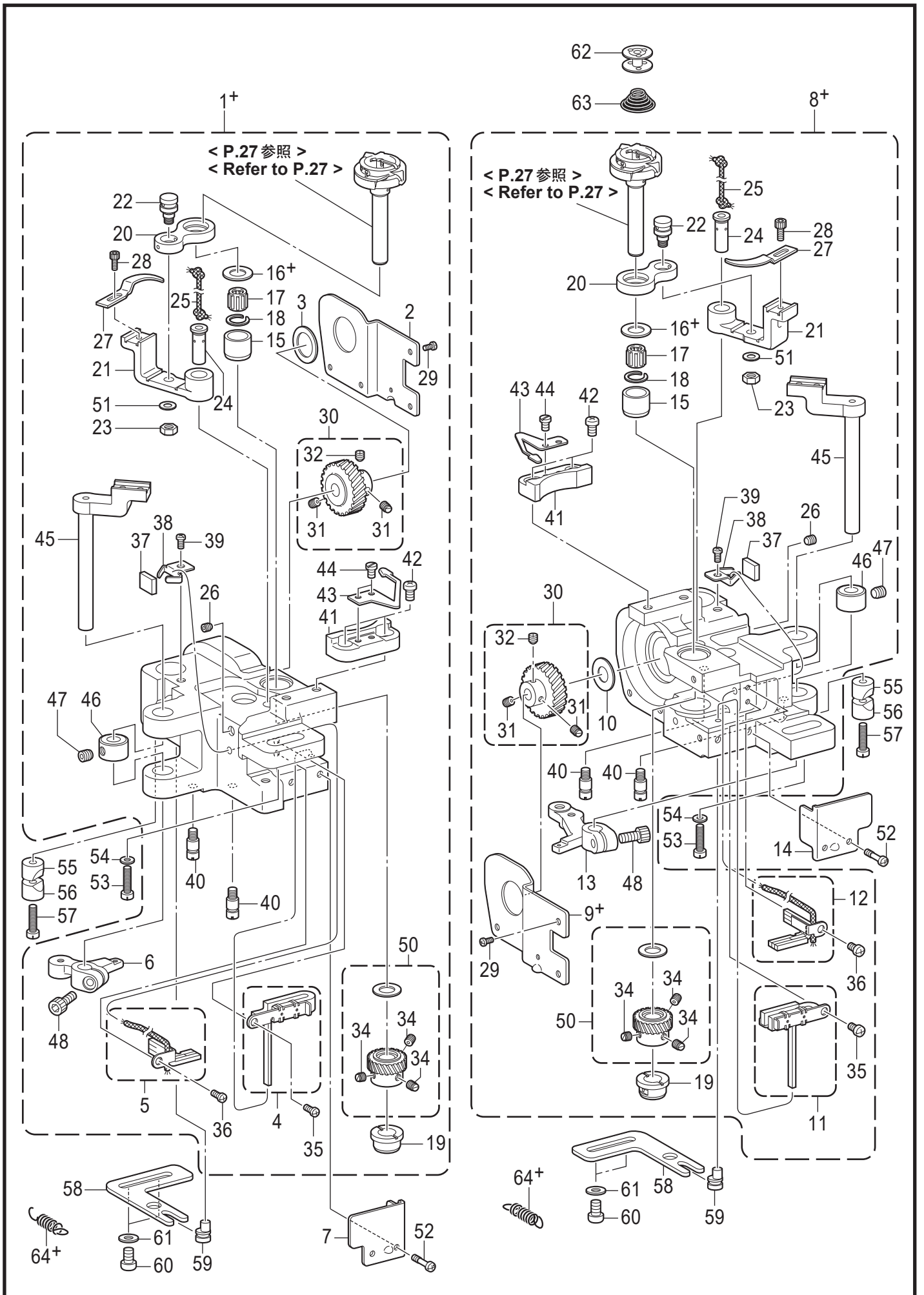



J2. かま関係 (T-8422D-40[]) / Rotary hook mechanism (T-8422D-40[])

REF.NO	CODE	Q'TY	品名	NAME OF PARTS	RM
1+	SB4827301	1	<かま土台(L)用> カマドダイ842TR-LクミC	<For Rotary hook base (L)> R-HOOK BASE ASSY 842TR(L) C	
2	SA2562201	1	カマドダイカバーL	ROTARY HOOK BASE COVER L	
3	SA3054001	1	スラストザガネL	THRUST WASHER, L	
4	SA6424201	1	フェルトULクミ	FELT UL ASSY	
5	SA4044001	1	フェルトDLクミ	FELT DL ASSY	
6	SA2671001	1	イトキリレバーL	THREAD TRIMMER LEVER, L	
7	SA6462001	1	カマドダイカバーFL	ROTARY HOOK BASE COVER FL	
8+	SB4828301	1	<かま土台(R)用> カマドダイ842TR-RクミC	<For Rotary hook base (R)> R-HOOK BASE ASSY 842TR(R) C	
9+	SA2563301	1	カマドダイカバーR	ROTARY HOOK BASE COVER R	
10	SA2579001	1	スラストザガネ	SPACER	
11	SA6425201	1	フェルトURクミ	FELT UR ASSY	
12	SA4045001	1	フェルトDRクミ	FELT DR ASSY	
13	SA2670101	1	イトキリレバーR	THREAD TRIMMER LEVER R	
14	SA6463001	1	カマドダイカバーFR	ROTARY HOOK BASE COVER FR	
15	SA4029001	2	カマジクメタルU	ROTARY HOOK SHAFT BUSH	
16+	S09260001	2	スラストリングA< t=1.2 >	THRUST RING A: 1.2MM < t=1.2 >	
16+	SA4038001	2	スラストリング< t=1.0 >	THRUST RING < t=1.0 >	
16+	S09261001	2	スラストリングB< t=1.4 >	THRUST RING, B 1.4MM < t=1.4 >	
16+	SA4444001	2	スラストリング0.8< t=0.8 >	THRUST RING 0.8MM < t=0.8 >	
17	S07420000	2	ニードルベアリング	NEEDLE BEARING	
18	S07419001	2	ストツプリング	RETAINING RING	
19	SA6474001	2	カマジクメタルD	ROTARY HOOK SHAFT BUSH	
20	SB4193001	2	オープナーリンク	OPENER LINK	
21	SA3859101	2	オープナーレバー	OPENER LEVER	
22	SA2560001	2	オープナーリンクジク	SHAFT O-LINK	
23	021500316	2	3シュナット5	NUT 3 M5	
24	SA3889101	2	オープナーレバージク	O-LEVER SHAFT	
25	SA4026001	2	クミヒモ4X4 L=100	WICK, 4X4 L=100	
26	012501031	2	アナヒラ5X10	SET SCREW SOCKET (FT) M5X10	
27	S38212001	2	オープナー	OPENER	
28	154965001	2	アナボルト3.57X8	BOLT, SOCKET SM3.57X8	
29	062300612	8	ナベコ3X6	SCREW PAN M3X6	
30	SA2572201	2	スパイラルギヤ ネジツキ	SPIRAL GEAR SCREW ASSY	
31	SA2574001	4	トメネジM6ホソメ	SET SCREW, (FT) M6	
32	SA2575101	2	トメネジM6ホソメ	SET SCREW (FT) M6	
34	SA2574001	6	トメネジM6ホソメ	SET SCREW, (FT) M6	
35	062400616	2	ナベコ4X6	SCREW PAN M4X6	
36	062400616	2	ナベコ4X6	SCREW PAN M4X6	
37	SA4012001	2	フェルト	FELT	
38	SA3894001	2	フェルトオサエ	FELT SUPPORT	
39	062400616	2	ナベコ4X6	SCREW PAN M4X6	
40	SA2717001	4	ストツパネジ	STOPPER SCREW	
41	SA2676001	2	イドウハウケ	MOVABLE KNIFE BRACKET	
42	062400812	4	ナベコ4X8	SCREW PAN M4X8	
43	S07525100	2	シタイトホジバネ	SPRING PLATE	
44	141544001	4	シメネジ3.18	SCREW, SM3.18-40X3	
45	SA3912001	2	イドウハレバー	MOVABLE KNIFE LEVER	
46	SA2675001	2	セットカラ	SET SCREW COLLAR	
47	S23651001	2	アナヒラ6X6ホソメ	SET SCREW SOCKET (FT) M6X6	
48	018501232	2	アナボルト5X12	BOLT SOCKET M5X12	
50	SA6307201	2	ピニオンセット	PINION GEAR SET	

J2. かま関係 (T-8422D-40[]) / Rotary hook mechanism (T-8422D-40[])

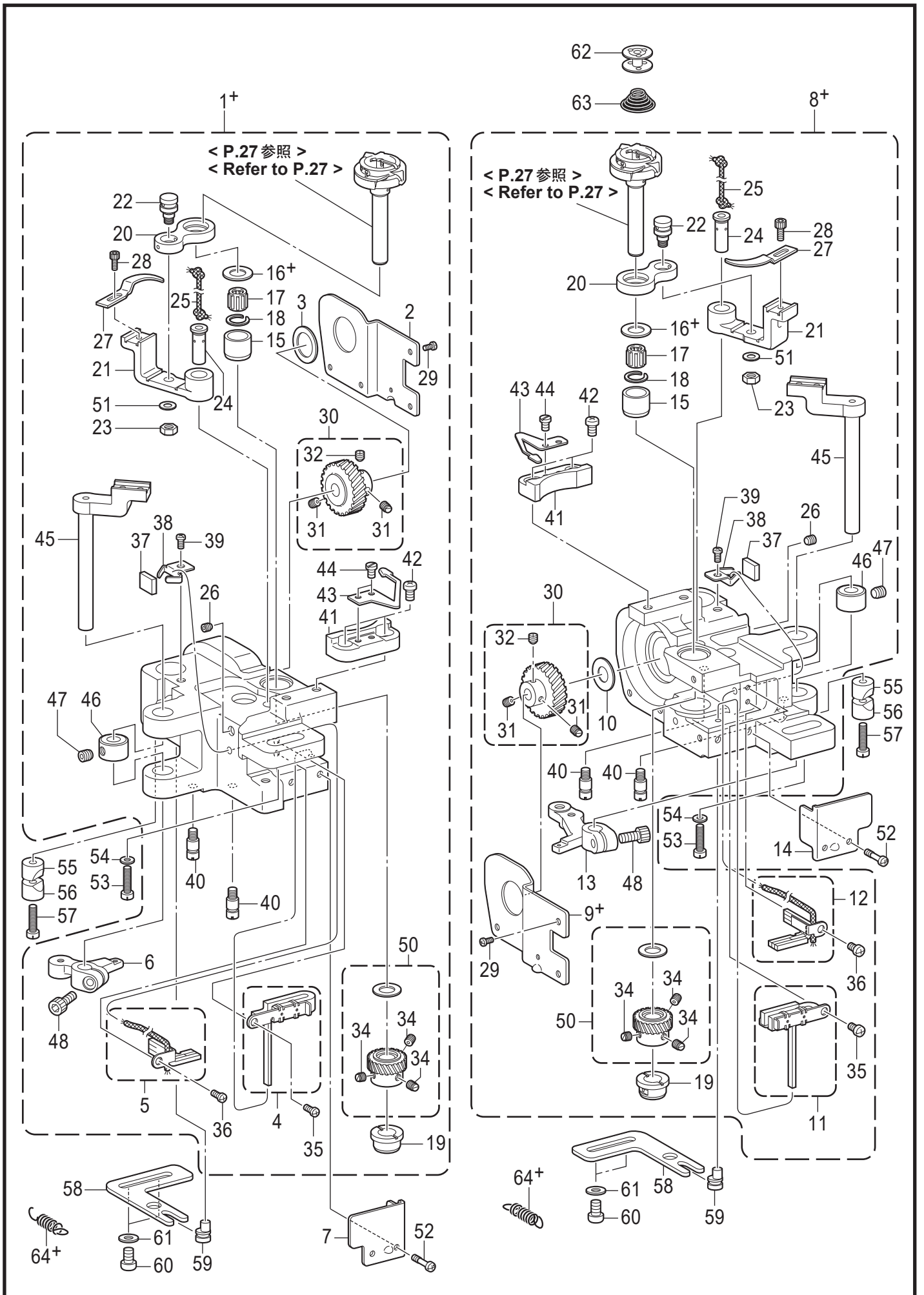

J2. かま関係 (T-8422D-40[]) / Rotary hook mechanism (T-8422D-40[])

REF.NO	CODE	Q'TY	品名	NAME OF PARTS	RM
51	SB2330001	2	ヒラザガネシヨウ4.76	WASHER PLAIN S SM4.76	
52	SA6417001	4	シメネジM4X12	SCREW M4X12	
53	SA2556001	2	シメネジM6X25	SCREW, M6X25	
54	115947101	2	ザガネ	WASHER PLAIN 6.35	
55	SA2722001	2	ピンチスリーブA	PINCH SLEEVE A	
56	SA2565001	2	ピンチスリーブB	PINCH SLEEVE B	
57	SA2556001	2	シメネジM6X25	SCREW, M6X25	
58	SA2567001	2	ハリスキチヨウセツイタ	NEEDLE UPPER ADJUSTING PLATE	
59	SA2568001	2	ハリスキチヨウセツジク	NEEDLE UPPER POSITIONING SHAFT	
60	062061016	4	ナベコ6X10	SCREW PAN M6X10	
61	025060136	4	ヒラザガネシヨウ6	WASHER PLAIN S 6	
62	S01928151	2	ボビン	BOBBIN	
63	148602001	2	クウテンボウシバネ	ANTI-SPIN SPRING	
64+	SA4458001	2	<-□03用> イトキリレバーバネB	<For -□03> SPRING EXTENSION B	
64+	SA2826001	2	<-□05,-S07用> イトキリレバーバネ	<For -□05,-S07> SPRING, EXTENSION	

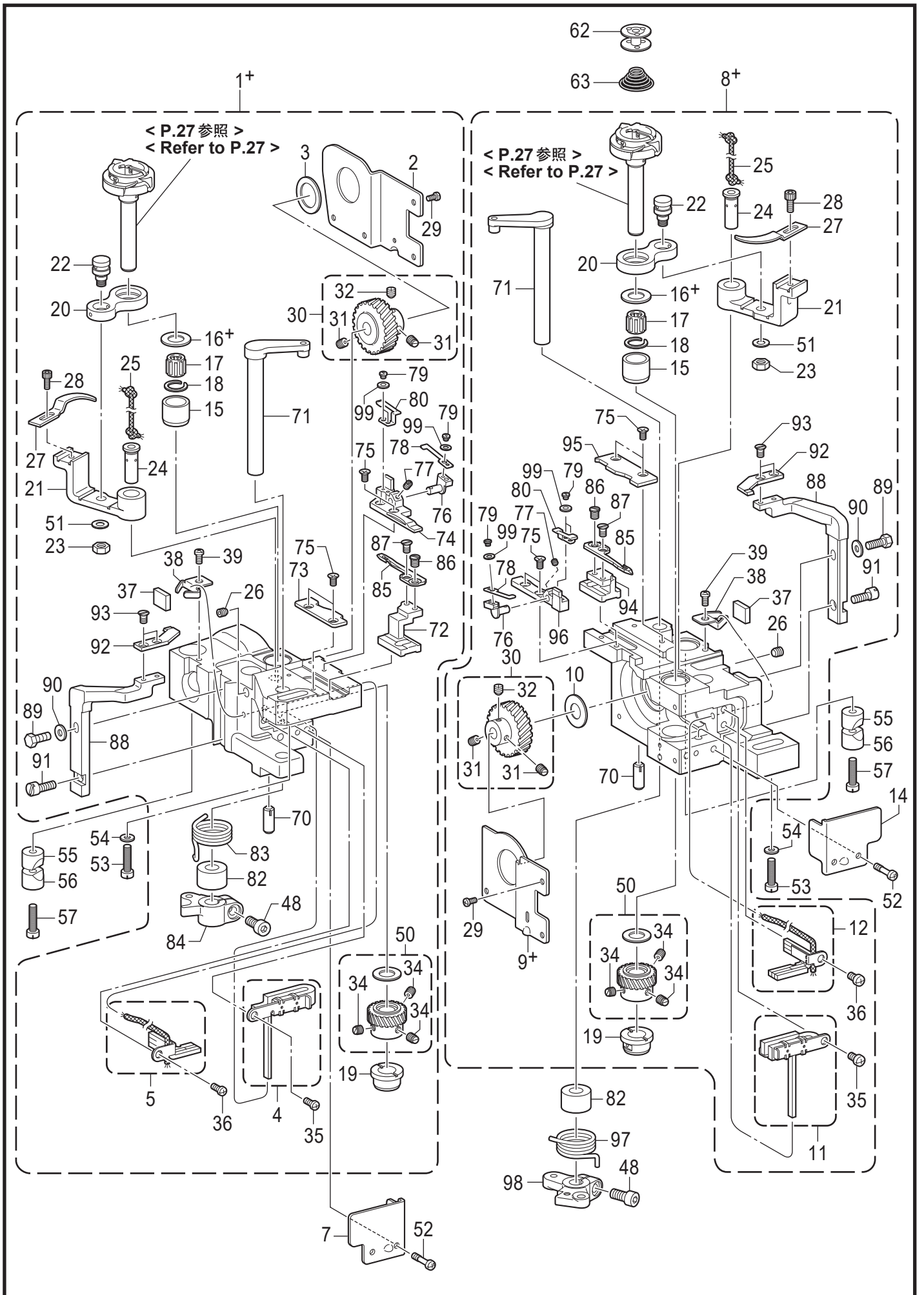

J2. かま関係 (T-8422D-S0[]) / Rotary hook mechanism (T-8422D-S0[])

REF.NO	CODE	Q'TY	品名	NAME OF PARTS	RM
1+	SC0700201	1	<かま土台(L)用> カマドダイ842STR-Lクミ	<For Rotary hook base (L)> R-HOOK BASE ASSY 842STR(L) D	
2	SA2562201	1	カマドダイカバーL	ROTARY HOOK BASE COVER L	
3	SA3054001	1	スラストザガネL	THRUST WASHER, L	
4	SA6424201	1	フェルトULクミ	FELT UL ASSY	
5	SA4044001	1	フェルトDLクミ	FELT DL ASSY	
7	SA6462001	1	カマドダイカバー-FL	ROTARY HOOK BASE COVER FL	
8+	SC0713201	1	<かま土台(R)用> カマドダイ842STR-Rクミ	<For Rotary hook base (R)> R-HOOK BASE ASSY 842STR(R) D	
9+	SC0704001	1	カマドダイカバー-R	ROTARY HOOK BASE COVER R	
10	SA2579001	1	スラストザガネ	SPACER	
11	SA6425201	1	フェルトURクミ	FELT UR ASSY	
12	SA4045001	1	フェルトDRクミ	FELT DR ASSY	
14	SA6463001	1	カマドダイカバー-FR	ROTARY HOOK BASE COVER FR	
15	SA4029001	2	カマジクメタルU	ROTARY HOOK SHAFT BUSH	
16+	S09260001	2	スラストリングA< t=1.2 >	THRUST RING A: 1.2MM < t=1.2 >	
16+	SA4038001	2	スラストリング< t=1.0 >	THRUST RING < t=1.0 >	
16+	S09261001	2	スラストリングB< t=1.4 >	THRUST RING, B 1.4MM < t=1.4 >	
16+	SA4444001	2	スラストリング0.8< t=0.8 >	THRUST RING 0.8MM < t=0.8 >	
17	S07420000	2	ニードルベアリング	NEEDLE BEARING	
18	S07419001	2	ストツプリング	RETAINING RING	
19	SA6474001	2	カマジクメタルD	ROTARY HOOK SHAFT BUSH	
20	SB4193001	2	オープナーリンク	OPENER LINK	
21	SA3859101	2	オープナーレバー	OPENER LEVER	
22	SA2560001	2	オープナーリンクジク	SHAFT O-LINK	
23	021500316	2	3シュナット5	NUT 3 M5	
24	SA3889101	2	オープナーレバージク	O-LEVER SHAFT	
25	SA4026001	2	クミヒモ4X4 L=100	WICK, 4X4 L=100	
26	012501031	2	アナヒラ5X10	SET SCREW SOCKET (FT) M5X10	
27	S38212001	2	オープナー	OPENER	
28	154965001	2	アナボルト3.57X8	BOLT, SOCKET SM3.57X8	
29	062300612	8	ナベコ3X6	SCREW PAN M3X6	
30	SA2572201	2	スパイラルギヤ ネジツキ	SPIRAL GEAR SCREW ASSY	
31	SA2574001	4	トメネジM6ホソメ	SET SCREW, (FT) M6	
32	SA2575101	2	トメネジM6ホソメ	SET SCREW (FT) M6	
34	SA2574001	6	トメネジM6ホソメ	SET SCREW, (FT) M6	
35	062400616	2	ナベコ4X6	SCREW PAN M4X6	
36	062400616	2	ナベコ4X6	SCREW PAN M4X6	
37	SA4012001	2	フェルト	FELT	
38	SA3894001	2	フェルトオサエ	FELT SUPPORT	
39	062400616	2	ナベコ4X6	SCREW PAN M4X6	
48	018501232	2	アナボルト5X12	BOLT SOCKET M5X12	
50	SA6307201	2	ピニオンセット	PINION GEAR SET	

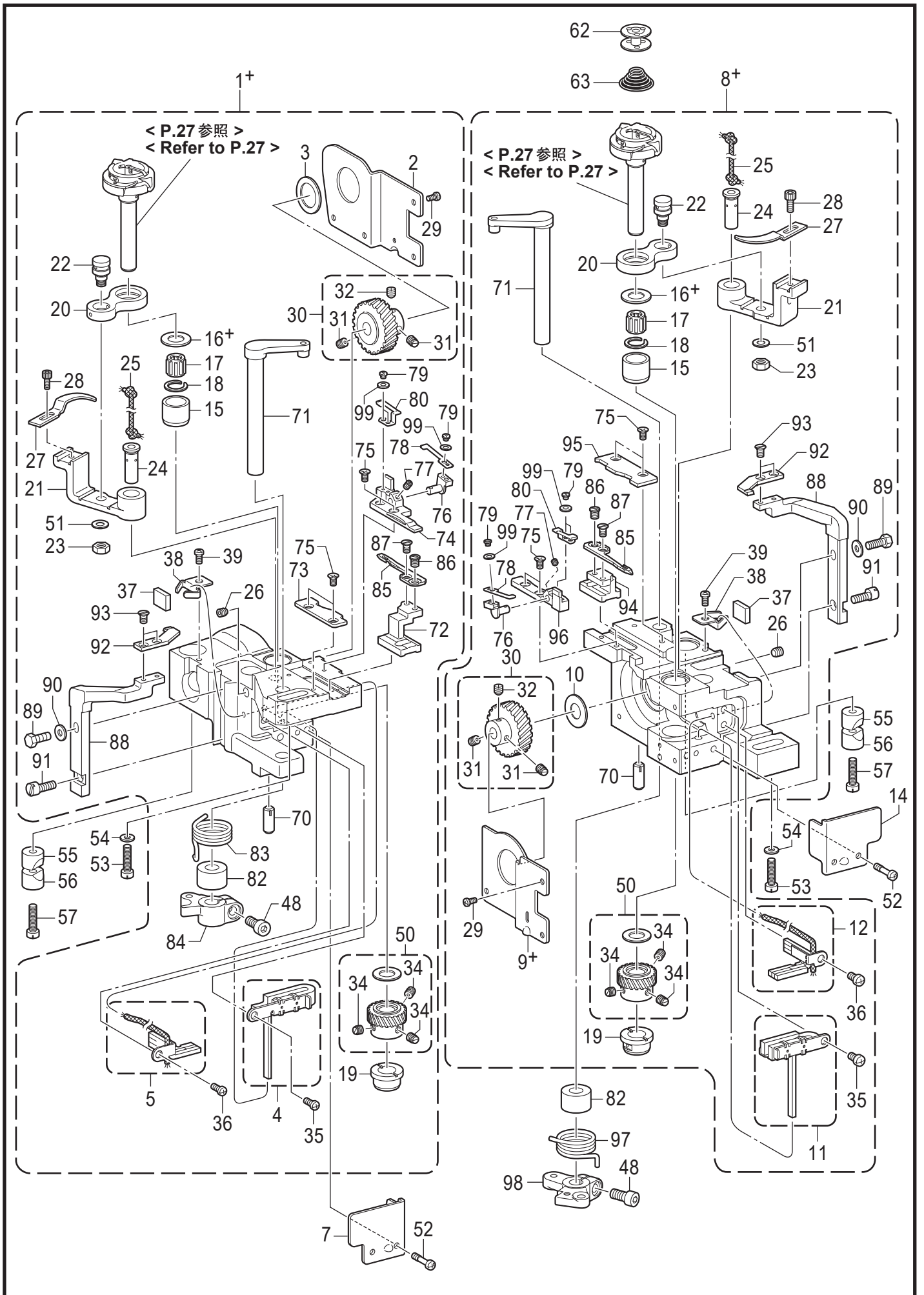

J2. かま関係 (T-8422D-S0[]) / Rotary hook mechanism (T-8422D-S0[])

REF.NO	CODE	Q'TY	品名	NAME OF PARTS	RM
51	SB2330001	2	ヒラザガネシヨウ4.76	WASHER PLAIN S SM4.76	
52	SA6417001	4	シメネジM4X12	SCREW M4X12	
53	SA2556001	2	シメネジM6X25	SCREW, M6X25	
54	115947101	2	ザガネ	WASHER PLAIN 6.35	
55	SA2722001	2	ピンチスリーブA	PINCH SLEEVE A	
56	SA2565001	2	ピンチスリーブB	PINCH SLEEVE B	
57	SA2556001	2	シメネジM6X25	SCREW, M6X25	
62	S01928151	2	ボビン	BOBBIN	
63	148602001	2	クウテンボウシバネ	ANTI-SPIN SPRING	
70	118550001	2	ミゾツキピン	PIN DOWEL	
71	SC0702001	2	イドウハレバークミ	MOVABLE KNIFE LEVER ASSY	
72	SC0706001	1	スライダール	SLIDER L	
73	SC0707001	1	スライダールオサエAL	PRESSER SLIDER AL	
74	SC0708101	1	スライダールオサエBL	PRESSER SLIDER BL	
75	S06696004	8	サラコ3X6	SCREW, FLAT M3X6	
76	SC0709001	2	シタイトホジドダイ	LOWER THREAD SUPPORT BASE	
77	012300336	2	アナヒラ3X3	SET SCREW SOCKET (FT) M3X3	
78	SC3881001	2	シタイトホジバネシタ	SPRING PLATE D	
79	S48247001	6	シメネジ2.38	SCREW SM2.38X5	
80	SC0711001	2	シタイトホジバネウエ	SPRING PLATE U	
82	SC0721001	2	カラー	COLLAR	
83	SC0720001	1	イトキリレバーバネ	SPRING EXTENSION	
84	SC0712001	1	イトキリレバール	THREAD TRIMMER LEVER L	
85	SC0728001	2	イドウハ	MOVABLE KNIFE	
86	SC2408001	2	シメネジ3.57-40X5	SCREW SM3.57-40X5	
87	SC4017001	2	サラネジ3.57X5	SCREW FLAT SM3.57X5	
88	SC0729001	2	コテイハドダイ	FIX KNIFE BASE	
89	017401415	2	ボルト4X14	BOLT M4X14	
90	026040236	2	ヒラザガネミガキ4	WASHER PLAIN M 4	
91	SC0730001	2	ヘンシンネジ	ECCENTRIC SCREW	
92	SC0731001	2	コテイハ	FIXED KNIFE	
93	SC4017001	4	サラネジ3.57X5	SCREW FLAT SM3.57X5	
94	SC0715001	1	スライダール	SLIDER R	
95	SC0716001	1	スライダールオサエAR	PRESSER SLIDER AR	
96	SC0717101	1	スライダールオサエBR	PRESSER SLIDER BR	
97	SC1762001	1	イトキリレバールバネ	SPRING EXTENSION R	
98	SC0719001	1	イトキリレバール	THREAD TRIMMER LEVER R	
99	SC0941001	6	ザガネ2.6	WASHER 2.6	

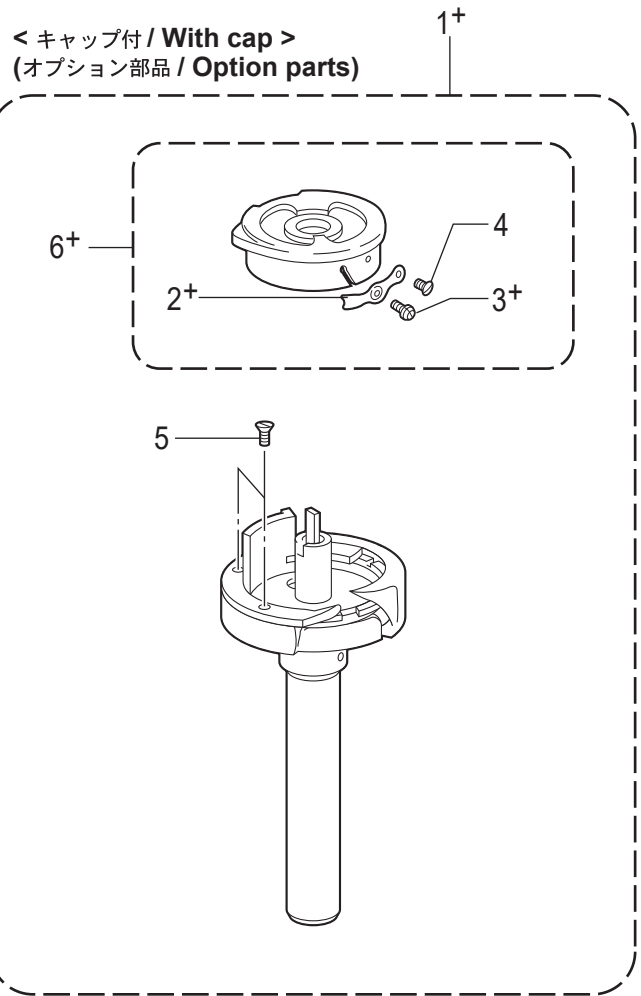
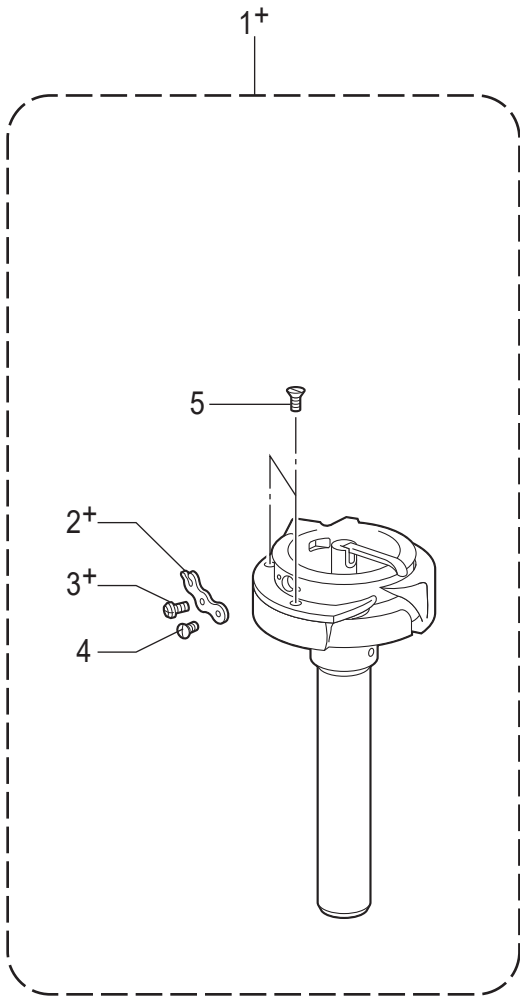



J3. かま関係 / Rotary hook mechanism

REF.NO	CODE	Q'TY	品名	NAME OF PARTS	RM
1+	* P.63-64	1	カマハコクミ	ROTARY HOOK ASSY	
2+	* P.63-64	1	チヨウシバネ	TENSION SPRING	
3+	* P.63-64	1	チヨウシネジ	TENSION ADJUSTING SCREW	
4	151030101	1	チヨウシバネトメネジ	SET SCREW	
5	151027101	2	ウチカマオサエトメネジ	SET SCREW	
6+	* P.63-64	1	<オプション部品> キャップクミ	<Option parts> BOBBIN CASE ASSY	

K. 下軸関係 / Lower shaft mechanism

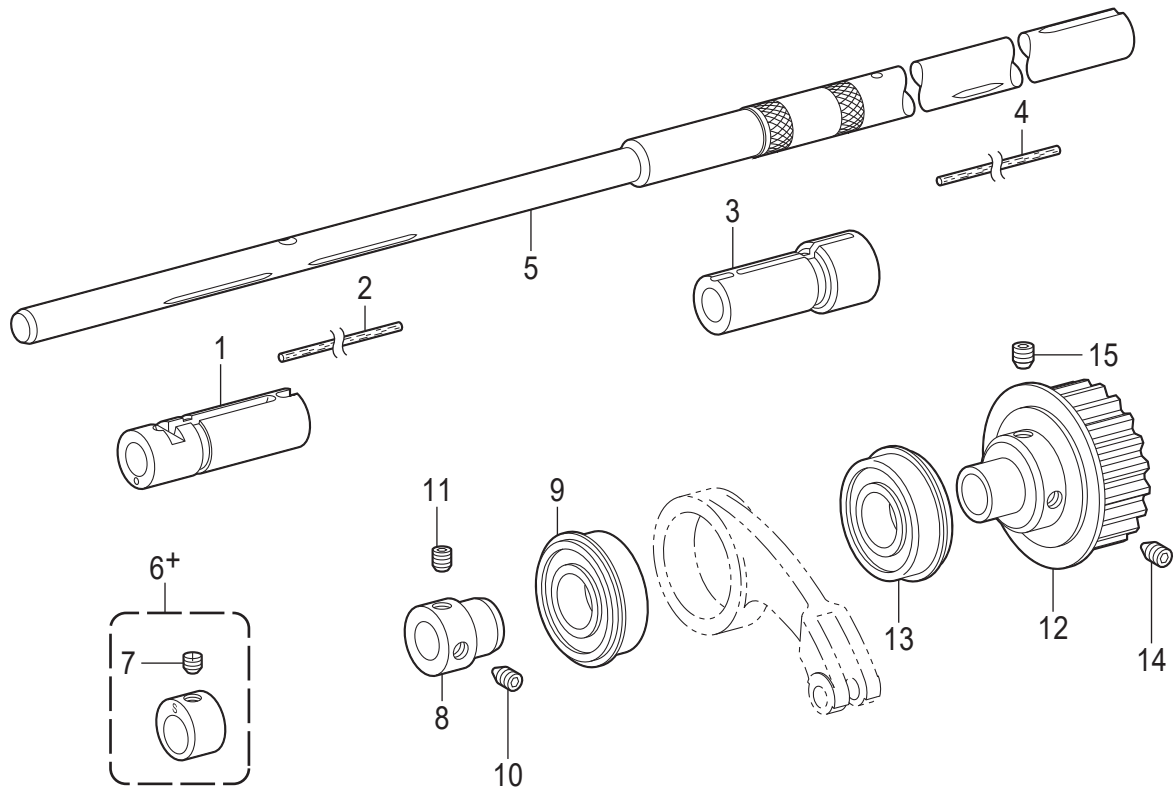

K. 下軸関係 / Lower shaft mechanism

REF.NO	CODE	Q'TY	品名	NAME OF PARTS	RM
1	SA3890001	1	カマドダイメタルL	ROTARY HOOK BASE BUSH, L	
2	SA4585001	1	フェルト	FELT	
3	SA3891001	1	カマドダイメタルR	ROTARY HOOK BASE BUSH, R	
4	SA4585001	1	フェルト	FELT	
5	SA2571101	1	シタジク	LOWER SHAFT	
6+	SA2759101	1	<T-8421D用> ジヨウゲヘンシンリンSTクミ	<For T-8421D> F-LIFTING ECCENTRIC WHEEL ASSY	
6+	SA2580101	1	<T-8422D用> ジヨウゲヘンシンリンTRクミ	<For T-8422D> F-LIFTING ECCENTRIC WHEEL ASSY	
7	SA2575001	1	トメネジM6ホソメ	SET SCREW (FT) M6	
8	SA2584001	1	タマジクウケブツシュ	BALL BEARING BUSH	
9	SB1535001	1	タマジクウケ6004ZZNR	BALL BEARING 6004ZZNR	
10	SA2585001	1	アナトガリ6X10ホソメ	SET SCREW, SOCKET (FT) M6	
11	S23651001	1	アナヒラ6X6ホソメ	SET SCREW SOCKET (FT) M6X6	
12	SA2587101	1	タイミングプーリDクミ	TIMING PULLEY ASSY, D	
13	SB1536001	1	タマジクウケ6204ZZNR	BALL BEARING 6204ZZNR	
14	SA2585001	1	アナトガリ6X10ホソメ	SET SCREW, SOCKET (FT) M6	
15	SA4213001	1	アナトメネジ6X10ホソメ	SET SCREW SOCKET (CP) M6X10	



## L. 給油潤滑関係 / Lubrication

REF.NO	CODE	Q'TY	品名	NAME OF PARTS	RM
			<-□□用>	<For - □□>	
1	SA4205101	1	オイルタンククミ	OIL TANK ASSY	
2	SA3040001	2	オイルクチ	OIL FEEDING PIPE	
3	SA5026101	1	ポンプフタネジ	SCREW M8X7	
4	SA3946001	1	キュウユタ-ミナル	OIL TERMINAL	
5	SA2956001	1	ビニルチューブ	OIL TUBE L=135	
6	SA2957001	2	フェルト	FELT	
7	SA3055101	2	チューブストツパー	TUBE CLIP	
8	SA6178001	2	クリップ	CLIP	
9	062500816	1	ナベコ5X8	SCREW PAN M5X8	
10	SA2929001	1	ゴムセン12.5	RUBBER CAP, 12.5	
11	S38266000	1	カマジクフェルト	ROTARY HOOK SHAFT FELT	
12	SA4215101	1	フェルトクミ	FELT ASSY	
13	SA4033101	1	フェルトオサエ	FELT SUPPORT	
14	228475000	1	ケツソクバンド1.9X80	FASTENING BAND 1.9X80	
			<-T3F用>	<For - T3F>	
15	SA5304001	1	オイルタンククミ	OIL TANK ASSY	
16	SA5026101	2	ポンプフタネジ	SCREW M8X7	
17	SA3040001	1	オイルクチ	OIL FEEDING PIPE	
18	SA3055101	1	チューブストツパー	TUBE CLIP	
19	SA2929001	2	ゴムセン12.5	RUBBER CAP, 12.5	
20	104450101	1	ゴムセン8	RUBBER CAP, 8	
21	081038070	1	OリングP38	O RING P38	
22	SA2723001	1	ビニルチューブ	OIL TUBE L=210	
23	SA2724001	1	クミヒモ	WICK, L=400	
24	0A5501006	2	+ナベザクミ5X10DB	SCREW PAN (S/P WASHER) M5X10	
26	SA6475001	2	オイルチヨウセツネジ	OIL ADJUSTING SCREW	
27	081004070	2	OリングP4	O RING P4	
28	SA6468001	2	ゴムパツキン	RUBBER PACKING	
29	SA6423001	2	カマジクフェルト	ROTARY HOOK SHAFT FELT	
30	SA6415001	2	クミヒモ	WICK L=80	
31	142274201	2	ゴムセン4.2	RUBBER CAP 4.2	
33	SA3040001	1	オイルクチ	OIL FEEDING PIPE	
34	SA3060001	1	バルブパツキン	VALVE PACKING	
35	104450101	1	ゴムセン8	RUBBER CAP, 8	
36	0A4400806	2	+ナベザクミ4X8DA	SCREW PAN (S/P WASHER) M4X8	
37	SA3045201	1	サブタンクトリツケイタA	SUB-TANK SETTING PLATE A	
38	SA3046001	1	サブタンクトリツケイタB	SUB-TANK SETTING PLATE, B	
39	062060816	2	ナベコ6X8	SCREW PAN M6X8	
40	SA3044001	1	ビニルチューブ	OIL TUBE L=242	
41	SA3055101	2	チューブストツパー	TUBE CLIP	
42	SA6472001	1	チューブササエ	TUBE SUPPORT	
43	SB4608001	2	カマドダイDパツキン	ROTARY HOOK BASE D PACKING	
44	062401616	4	ナベコ4X16	SCREW PAN M4X16	
45	SA2604001	1	キリカエキフェルト	FEED REGULATOR FELT	
46	SA2605001	1	フェルトオサエイタ	FELT SUPPORT	
47	062500616	1	ナベコ5X6	SCREW PAN M5X6	
48	109405001	1	クミヒモ4X4	WICK 4X4 (L=100)	
49	108801001	1	クミヒモ4X4	WICK, 4X4 L=350	
50	SA2606101	1	オイルカバー	OIL COVER	
51	104450101	1	ゴムセン8	RUBBER CAP, 8	
52	SA3048101	1	チューブオサエA	TUBE SUPPORT, A	
53	SA3049001	1	チューブオサエB	TUBE SUPPORT, B	
54	062400616	1	ナベコ4X6	SCREW PAN M4X6	
55	SA6473001	1	チューブガイド	TUBE GUIDE	
56	140890009	1	オイルカツブ	OIL CAP	
57	112753001	2	フェルト	FELT	



## L. 給油潤滑関係 / Lubrication

REF.NO	CODE	Q'TY	品名	NAME OF PARTS	RM
58	062061016	3	ナベコ6X10	SCREW PAN M6X10	
59	025060236	1	ヒラザガネチュー6	WASHER PLAIN M 6	
60	SA6423001	2	カマジクフェルト	ROTARY HOOK SHAFT FELT	
61	SA6416001	2	ゴムオサエ	RUBBER PRESSER	
62	SA6414001	4	チューブストツパー	TUBE CLIP	
63	140327001	2	ゴムセン6.3	RUBBER CAP, 6.3	
64	148743001	2	フェルト	FELT	
65	SA6465001	1	キューユブロツクL	OIL BLOCK L	
66	SA6467001	1	キューユブロツクR	OIL BLOCK R	
67	SA6422001	2	オイルクチ3.8	OIL FEEDING PIPE 3.8	
68	SA6470101	1	サブタンククミ	SUB-TANK ASSY	
69	SA6412001	1	ビニルチューブ	OIL TUBE L=400	
70	SA6411001	1	ビニルチューブ	OIL TUBE L=500	
71	SA6413001	1	フェルト	FELT L=1050	

M. 糸通し関係 / Threading mechanism

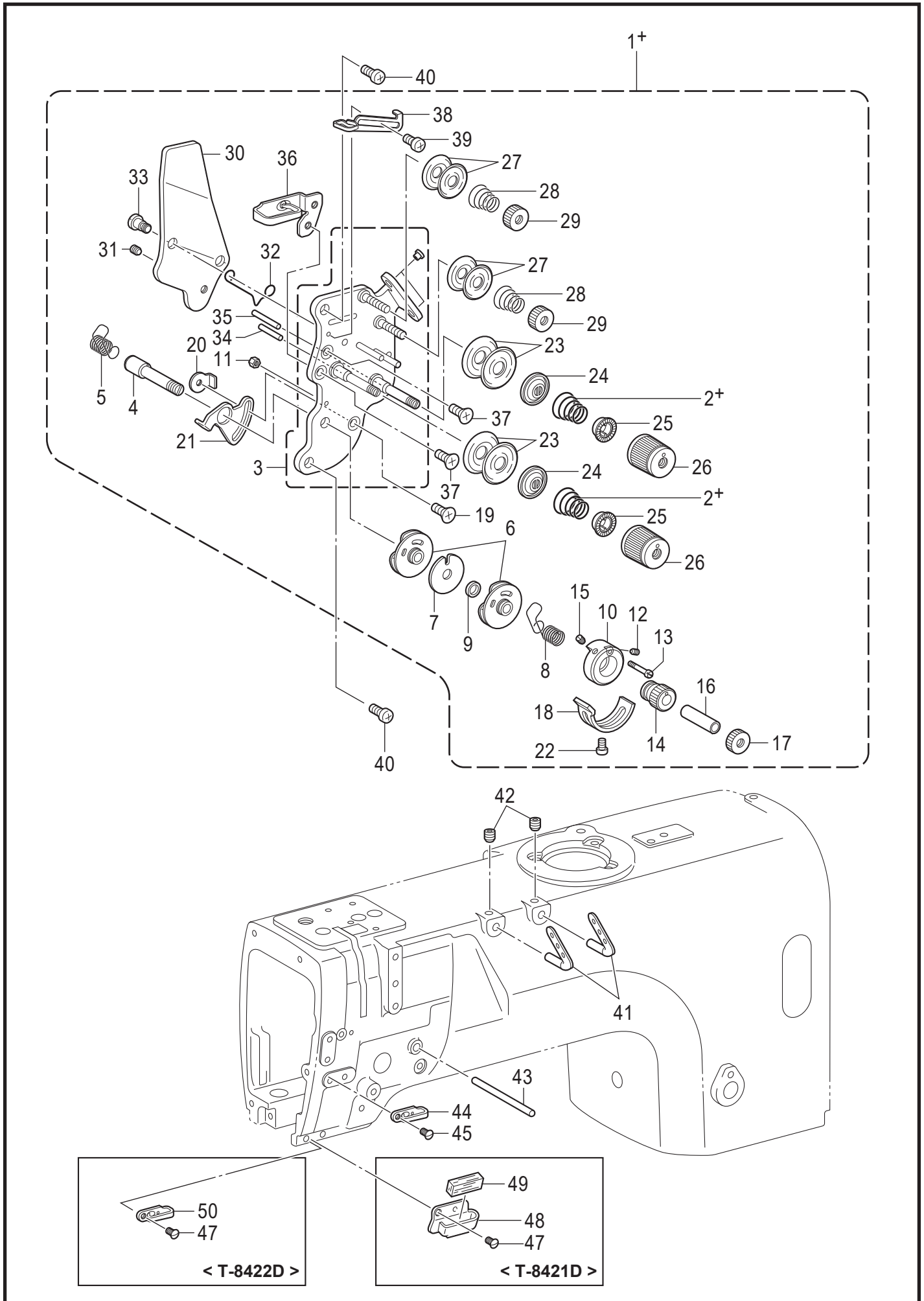

T-8421D/8422D-401



M. 糸通し関係 / Threading mechanism

REF.NO	CODE	Q'TY	品名	NAME OF PARTS	RM
1+	SA3417501	1	<-□03用> ウワイトチヨウシクミ-3	<For -□03> UPPER THREAD TENSION ASSY -3	
2+	SA3415001	2	イトチヨウシバネL	TENSION SPRING, L	
1+	SA2607501	1	<-□05,-S07用> ウワイトチヨウシクミ-5	<For -□05,-S07> UPPER THREAD TENSION ASSY -5	
2+	SA3416101	2	イトチヨウシバネLL	TENSION SPRING LL	
1+	SA2818501	1	<-T□F用> ウワイトチヨウシクミ-1	<For -T□F> UPPER THREAD TENSION ASSY -1	
2+	SA3414101	2	イトチヨウシバネM	TENSION SPRING M	
3	SA4212001	1	イトチヨウシダイクミ	TENSION PLATE ASSY	
4	SA2613101	1	チヨウシジク	TENSION STUD	
5	SA2614201	1	イトトリバネL	THREAD TAKE-UP SPRING L	
6	SA2615001	2	イトトリバネアンナイクミ	GUIDE ASSY, T/TAKE-UP SPRING	
7	SA2619001	1	スペーサー	SPACER	
8	SA2623201	1	イトトリバネR	THREAD TAKE-UP SPRING R	
9	SA2620001	1	カラ-	COLLAR	
10	SA2621001	1	ストツパウケ	STOPPER SUPPORT	
11	021300106	1	1シュナット3	NUT 1 M3	
12	SA2626001	1	トメネジ3.5	SET SCREW (CP) M3.5	
13	SA2624001	1	バネアンナイトメネジ	SPRING GUIDE SET SCREW	
14	SA2625001	1	チヨウセツツマミ	ADJUSTING THUMB	
15	SA2626001	1	トメネジ3.5	SET SCREW (CP) M3.5	
16	SA2627001	1	カラ-	COLLAR	
17	SA2628001	1	イトチヨウシナット	TENSION NUT	
18	SA2629001	1	イトトリバネストツパ	STOPPER	
19	004350616	1	+サラコ3.5X6	SCREW FLAT M3.5X6	
20	SA2824001	1	マワリドメナットM3.5	NUT, WHIRL-STOP M3.5	
21	SA2630001	1	イトトリバネストツパ	STOPPER	
22	062350516	1	ナベコ35X5	SCREW PAN M3.5X5	
23	145446002	4	イトチヨウシサラ	DISC TENSION	
24	159805001	2	イトチヨウシサラオサエ	TENSION DISC PRESSER	
25	S20681000	2	チヨウシバネウエザガネ	WASHER	
26	S20682111	2	イトチヨウシナット	TENSION NUT	
27	144504001	4	イトアンナイサラ	THREAD GUIDE DISC	
28	154560101	2	プレテンションバネA	PRE-TENSION SPRING A	
29	155510001	2	イトチヨウシナット	TENSION NUT	
30	SA2632001	1	イトユルメイタ	TENSION RELEASE PLATE	
31	012500536	1	アナヒラ5X5	SET SCREW SOCKET (FT) M5X5	
32	S38274001	1	イトユルメバネ	T-RELEASE SPRING	
33	SA2633001	2	ダンネジ3.5	SHOULDER SCREW M3.5	
34	SA4506001	1	イトユルメピンL	TENSION RELEASE PIN, L	
35	SA4507001	1	イトユルメピンR	TENSION RELEASE PIN, R	
36	SA2634001	1	ア-ムイトアンナイU	THREAD GUIDE, U: ARM	
37	004350616	2	+サラコ3.5X6	SCREW FLAT M3.5X6	
38	SA2635001	1	イトリヨウチヨウセイ	THREAD QUANTITY ADJUST	
39	062300616	1	ナベコ3X6	SCREW PAN M3X6	
40	062500816	2	ナベコ5X8	SCREW PAN M5X8	
41	SA2636001	2	ミツメイトカケ	THREAD RETAINER	
42	012060636	2	アナヒラ6X6	SET SCREW SOCKET (FT) M6X6	
43	SA2637001	1	イトユルメジク	BAR, TENSION RELEASE	
44	SA2638001	1	ア-ムイトアンナイM	THREAD GUIDE, M: ARM	
45	SA2640001	1	サラネジ5X8	SCREW FLAT M5X8	
47	SA2640001	1	サラネジ5X8	SCREW FLAT M5X8	
48	SA2639001	1	<T-8421D用> ア-ムイトアンナイD	<For T-8421D> THREAD GUIDE, D: ARM	
49	114941001	1	ア-ムイトアンナイフェルト	FELT	
50	SA2638001	1	<T-8422D用> ア-ムイトアンナイM	<For T-8422D> THREAD GUIDE, M: ARM	

N. 糸巻関係 / Bobbin winder mechanism

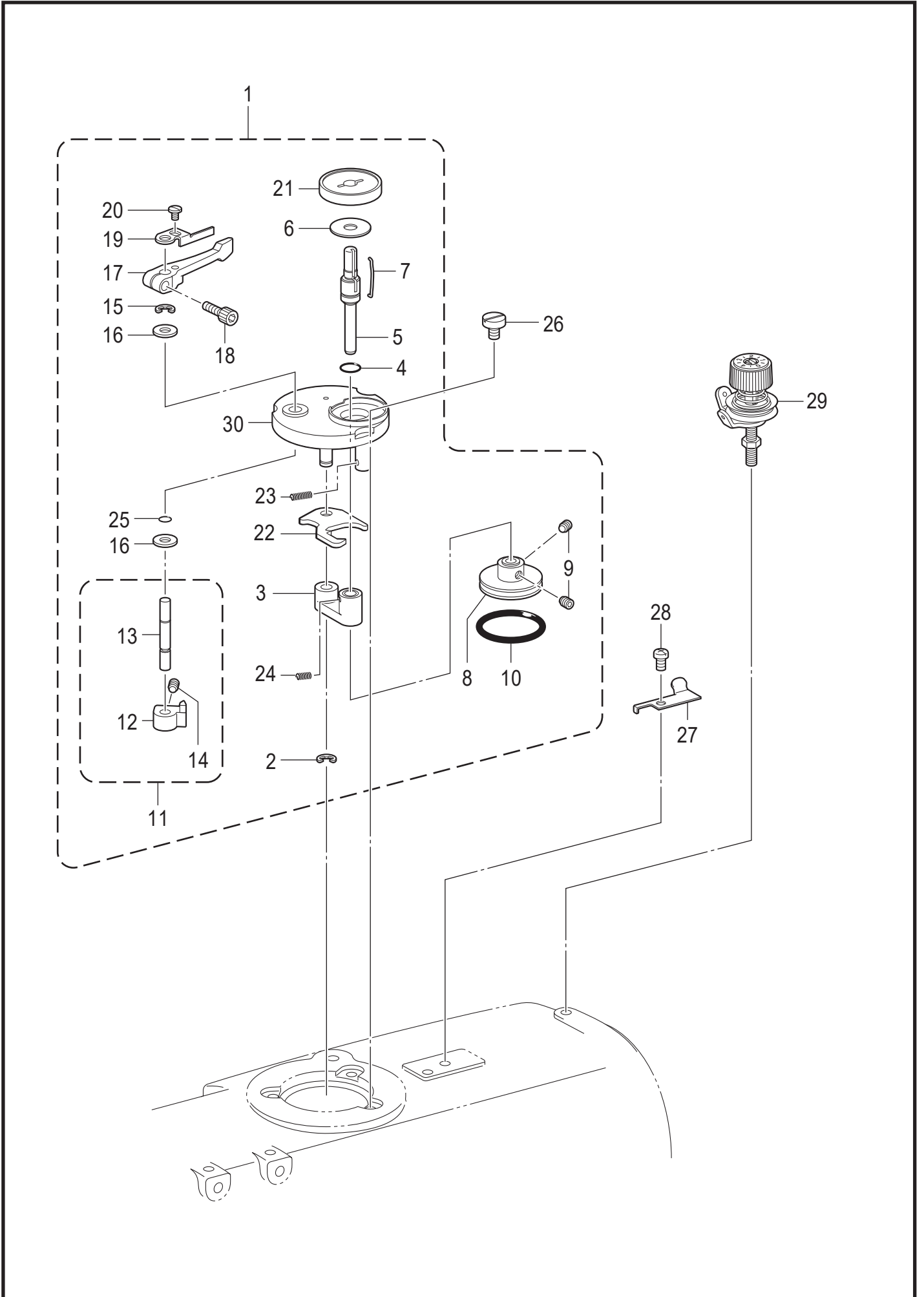

T-8421D/8422D-402

## N. 糸巻関係 / Bobbin winder mechanism

REF.NO	CODE	Q'TY	品名	NAME OF PARTS	RM
1	SB2245002	1	イトマキユニット	BOBBIN WINDER UNIT	
2	048040342	1	トメワE4	RETAINING RING E4	
3	SA8508001	1	イトマキジクウケクミ	B-WINDER SHAFT SUPPORT ASSY	
4	108549001	1	Oリング	O RING	
5	SB2247001	1	イトマキジク	BOBBIN WINDER SHAFT	
6	SB2275001	1	シート	SHEET	
7	SA9563001	1	ボビンコテイバネ	BOBBIN FIXED SPRING	
8	SA8507001	1	イトマキクルマ	BOBBIN WINDER WHEEL	
9	012400636	2	アナヒラ4X6	SET SCREW SOCKET (FT) M4X6	
10	SA8503001	1	ゴムリング	RUBBER RING	
11	SA1981301	1	ボビンオサエカムクミ	BOBBIN PRESSER CAM ASSY	
12	SA1982101	1	ボビンオサエカム	BOBBIN PRESSER CAM	
13	SA1983201	1	イトマキウデジク	BOBBIN WINDER ARM SHAFT	
14	012500536	1	アナヒラ5X5	SET SCREW SOCKET (FT) M5X5	
15	048040342	1	トメワE4	RETAINING RING E4	
16	025060136	2	ヒラザガネショウ6	WASHER PLAIN S 6	
17	SA1984001	1	ボビンオサエウデ	BOBBIN PRESSER ARM	
18	018401236	1	アナボルト4X12	BOLT SOCKET M4X12	
19	SA1985001	1	ボビンオサエ	BOBBIN PRESSER	
20	S23418002	1	シメネジ4X5	SCREW M4X5	
21	SB2246001	1	ボビンウケ	BOBBIN SUPPORT	
22	SA8512101	1	イトマキレバー	BOBBIN WINDER LEVER	
23	SA1990101	1	モドシバネ	SPRING	
24	SA8509001	1	イトマキダイバネ	BOBBIN WINDER BASE SPRING	
25	SA2190001	1	OリングSS5	O RING SS5	
26	SA1992101	3	イトマキコテイネジ	BOBBIN WINDER FIXED SCREW	
27	SA1360101	1	メス	KNIFE	
28	062500616	1	ナベコ5X6	SCREW PAN M5X6	
29	SB3571101	1	イトマキチヨウシクミ	BOBBIN WINDER TENSION ASSY	
30	SA8982202	1	イトマキダイ	BOBBIN WINDER BASE	

P. 糸切り関係 / Thread trimmer mechanism

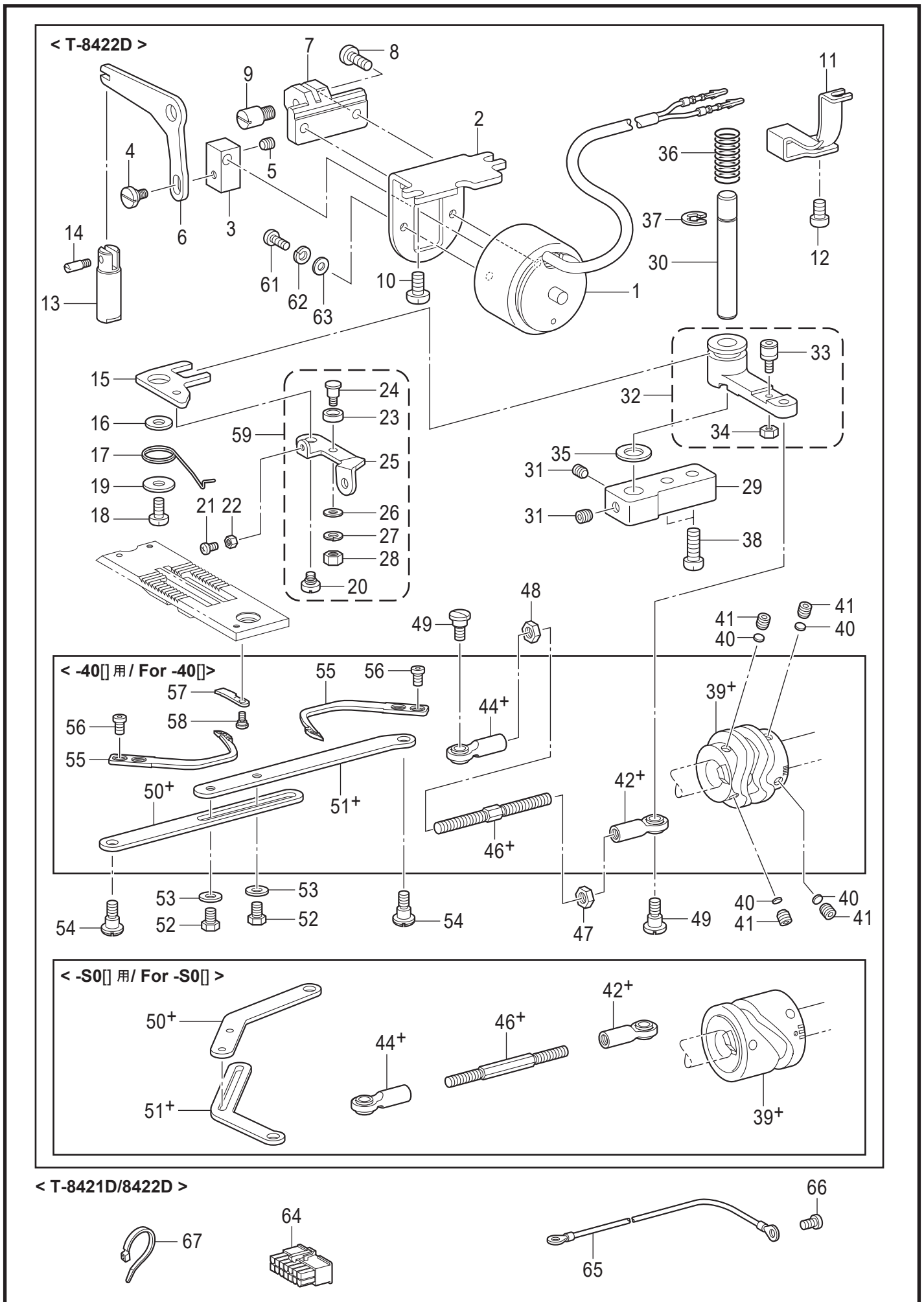

P. 糸切り関係 / Thread trimmer mechanism

REF.NO	CODE	Q'TY	品名	NAME OF PARTS	RM
			<T-8422D用>	<For T-8422D>	
1	SB9907001	1	イトキリソレノイド	THREAD TRIMMER SOLENOID	
2	SA2643001	1	ソレノイドシジイタ	SOLENOID BRACKET	
3	SA2644001	1	ソレノイドツギテ	SOLENOID JOINT	
4	SA2645001	1	ダンネジM5	SHOULDER SCREW, M5	
5	012500536	1	アナヒラ5X5	SET SCREW SOCKET (FT) M5X5	
6	SA2646001	1	ソレノイドレバー	SOLENOID LEVER	
7	SA2728001	1	ソレノイドレバーウケ	SOLENOID LEVER BRACKET	
8	062501016	2	ナベコ5X10	SCREW PAN M5X10	
9	SA2647001	1	ソレノイドレバージク	SOLENOID LEVER SHAFT	
10	062061012	2	ナベコ6X10	SCREW PAN M6X10	
11	SA2648001	1	コードオサエ	CORD HOLDER	
12	062060816	1	ナベコ6X8	SCREW PAN M6X8	
13	SA2651001	1	イトキリジク	DRIVING ROD	
14	148546001	1	プランジヤピン	PLUNGER PIN	
15	SA2652101	1	イトキリジクイタ	DRIVING ROD PLATE, TR	
16	SA2860001	1	ザガネ	WASHER	
17	SA6395001	1	イトユルメレバーバネ	SPRING	
18	062501016	1	ナベコ5X10	SCREW PAN M5X10	
19	116662003	1	ザガネ	WASHER	
20	SA2655001	1	ダンネジM4	SHOULDER SCREW, M4	
21	062351216	1	ナベコ35X12	SCREW PAN M3.5X12	
22	021350106	1	1シュナット35	NUT 1 M3.5	
23	SA6392001	1	イトユルメコロ	ROLLER	
24	SA6393001	1	イトユルメコロジク	ROLLER SHAFT	
25	SA6394001	1	イトユルメレバー	TENSION RELEASE LEVER	
26	113431002	1	ザガネ	WASHER, PLAIN	
27	028050246	1	バネザガネ2-5	WASHER SPRING 2-5	
28	021500106	1	1シュナット5	NUT 1 M5	
29	SA2657001	1	シユレバージクササエ	MAIN LEVER SUPPORT SHAFT	
30	SA2658001	1	シユレバージク	MAIN LEVER SHAFT	
31	012060636	2	アナヒラ6X6	SET SCREW SOCKET (FT) M6X6	
32	SB1450001	1	シユレバークミ	MAIN LEVER ASSY	
33	SB1452001	1	コロジククミ	ROLLER SHAFT ASSY	
34	105234003	1	ナット4.37	NUT SM4.37	
35	148559100	1	ゴム	RUBBER	
36	S07509001	1	シユレバーバネ	MAIN LEVER SPRING	
37	048070342	1	トメフE7	RETAINING RING E7	
38	062061616	2	ナベコ6X16	SCREW PAN M6X16	
40	SA2378001	4	カンザ4.8	SPACER, 4.8	
41	S25236001	4	アナヒラ6X10ホソメ	SET SCREW SOCKET (FT) M6X10	
47	021060306	1	3シュナット6	NUT 3 M6	
48	SA2668001	1	ナット6ヒダリ	NUT M6 LEFT	
49	SA2669001	2	タマツギテダンネジ	SHOULDER SCREW M6	
52	017500812	2	ボルト5X8	BOLT M5X8	
53	SB3849001	2	ヒラザガネチュウ5	WASHER_PLAIN_M_5	
54	SA2645001	2	ダンネジM5	SHOULDER SCREW, M5	
59	SA8364001	1	イトユルメレバークミ	TENSION RELEASE LEVER ASSY	
61	060400816	2	バインド4X8	SCREW BIND M4X8	
62	028040246	2	バネザガネ2-4	WASHER SPRING 2-4	
63	SB3848001	2	ヒラザガネチュウ4	WASHER_PLAIN_M_4	

P. 糸切り関係 / Thread trimmer mechanism

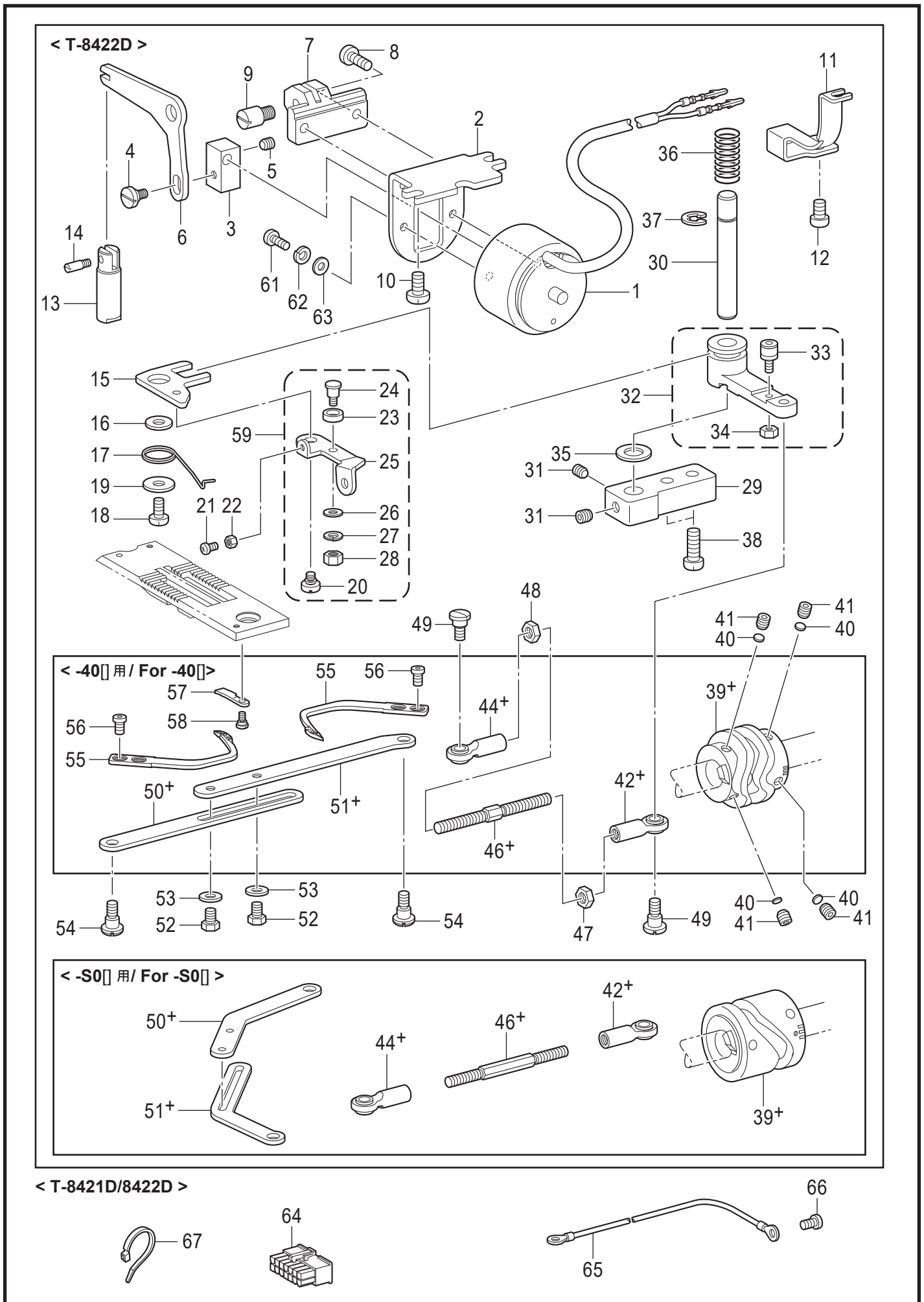

P. 糸切り関係 / Thread trimmer mechanism

REF.NO	CODE	Q'TY	品名	NAME OF PARTS	RM
64	S38687000	1	<T-8421D, T-8422D用> コネクタ5557-14R	<For T-8421D, T-8422D> CONNECTOR 5557-14R	
65	SB8436001	1	アースセンAWG8	GROUND WIRE AWG8	
66	062400816	1	ナベコ4X8	SCREW PAN M4X8	
67	SB4155001	1	<T-8421D用> バンド	<For T-8421D> BAND	
67	SB4155001	2	<T-8422D用> バンド	<For T-8422D> BAND	
39+	SB4152001	1	<-40□用> イトキリカム	<For -40□> THREAD TRIMMER CAM	
42+	SA2663001	1	タマツギテRクミ	ROUND JOINT ASSY R	
44+	SA2665001	1	タマツギテLクミ	ROUND JOINT ASSY L	
46+	SA2667001	1	ナガサチヨウセツレンカン	L-ADJUSTING CONNECTING ROD	
50+	SA2672001	1	イトキリレンカンR	T-TRIMMER CONNECTING ROD, R	
51+	SA2673001	1	イトキリレンカンL	T-TRIMMER CONNECTING ROD, L	
55	S07526301	2	イドウハ	MOVABLE KNIFE	
56	148536001	4	シメネジ4.37	SCREW, W/SOCKET SM4.37-40X4.2	
57	S07527001	2	コテイハ	FIXED KNIFE	
58	148539101	2	ダンネジ2.38	SHOULDER SCREW SM2.38	
39+	SC0722001	1	<-S0□用> イトキリカム	<For -S0□> THREAD TRIMMER CAM	
42+	SC0736001	1	タマツギテRクミ	ROUND JOINT ASSY R	
44+	SC0743001	1	タマツギテLクミ	ROUND JOINT ASSY L	
46+	SC0724001	1	ナガサチヨウセツレンカン	L-ADJUSTING CONNECTING ROD	
50+	SC0727001	1	イトキリレンカンR	T-TRIMMER CONNECTING ROD R	
51+	SC0726001	1	イトキリレンカンL	T-TRIMMER CONNECTING ROD L	

Q.糸緩め関係 (T-8422D) / Tension release mechanism (T-8422D)

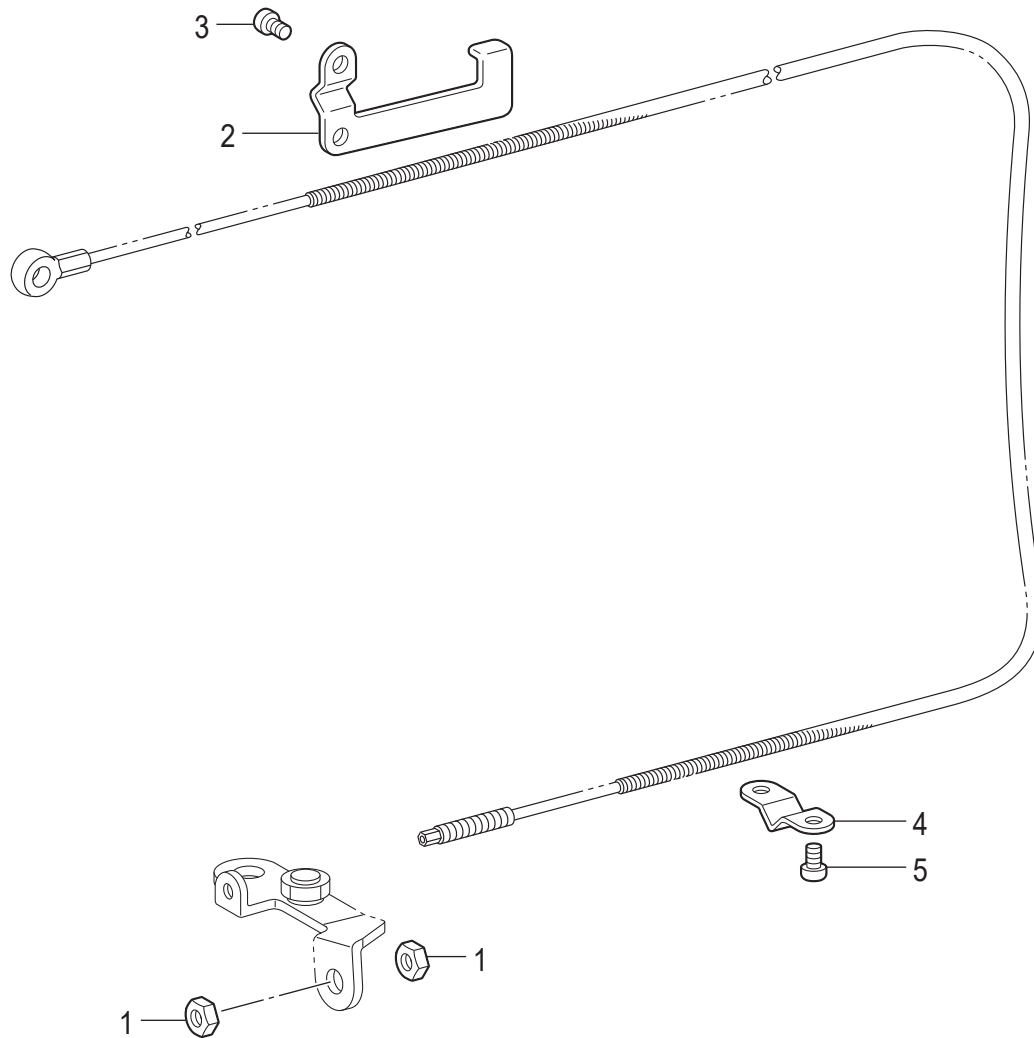

T-8422D-404



Q. 糸緩め関係 (T-8422D) / Tension release mechanism (T-8422D)

REF.NO	CODE	Q'TY	品名	NAME OF PARTS	RM
1	110161004	2	ナツト4.76	NUT SM4.76	
2	SA2678001	1	イトユルメワイヤ-オサエ	TENSION RELEASE WIRE HOLDER	
3	062500816	2	ナベコ5X8	SCREW PAN M5X8	
4	SA2679001	1	イトユルメワイヤ-オサエ	TENSION RELEASE WIRE HOLDER	
5	062060816	2	ナベコ6X8	SCREW PAN M6X8	

R. 糸払い関係(T-8422D) / Thread wiper mechanism (T-8422D)

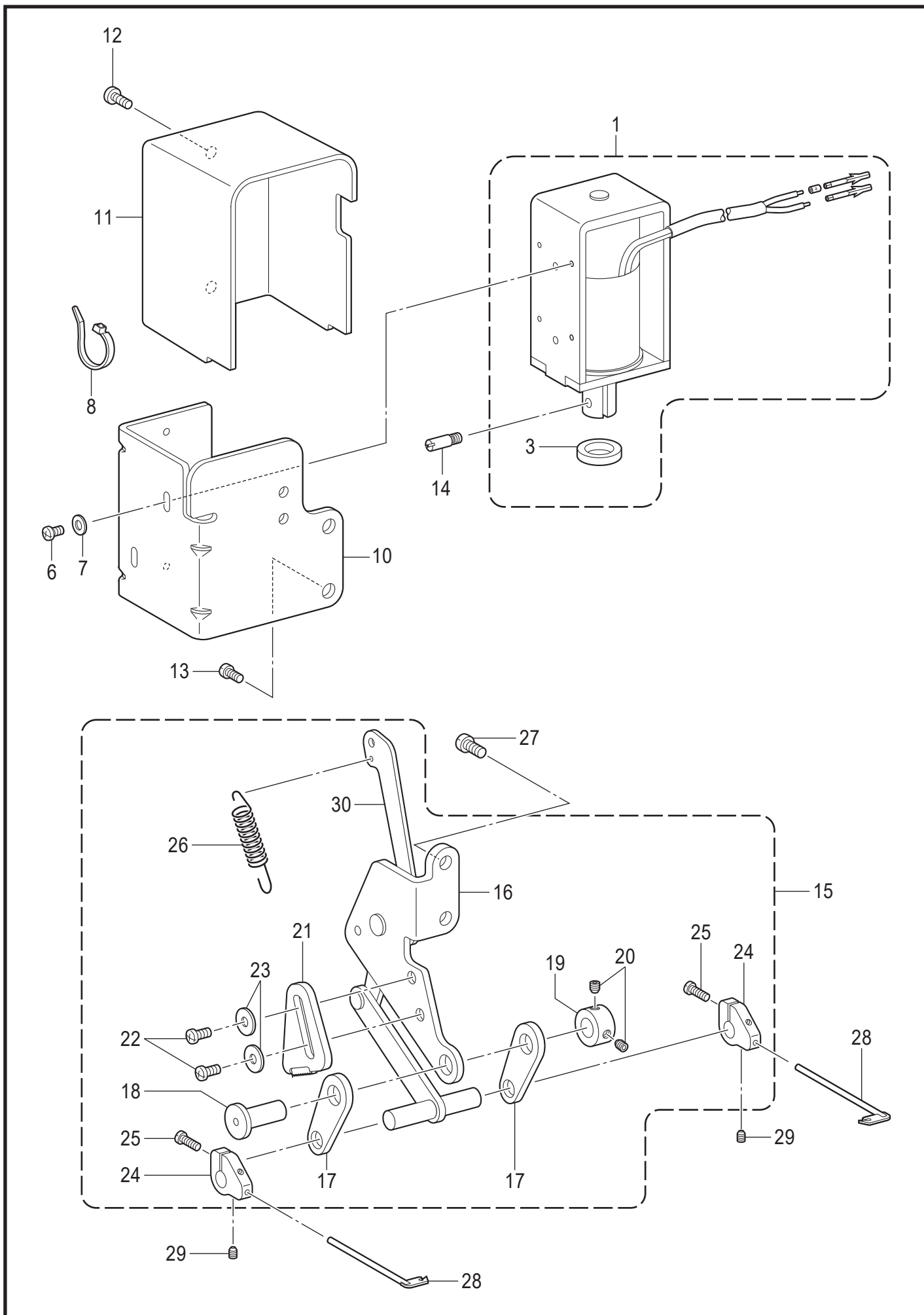

T-8422D-405

## R. 糸払い関係 (T-8422D) / Thread wiper mechanism (T-8422D)

REF.NO	CODE	Q'TY	品名	NAME OF PARTS	RM
1	SB9910001	1	イトハライソレノイドクミ	THREAD WIPER SOLENOID ASSY	
3	SA7235001	1	ソレノイドクツシヨシ	CUSHION SOLENOID	
6	062300616	2	ナベコ3X6	SCREW PAN M3X6	
7	026030233	2	ヒラザガネミガキ3	WASHER PLAIN M 3	
8	SB4155001	1	バンド	BAND	
10	SB4105001	1	ソレノイドホジイタ	SOLENOID HOLDING PLATE	
11	SB4104001	1	ソレノイドカバー	SOLENOID COVER	
12	060400516	2	バインド4X5	SCREW BIND M4X5	
13	062501016	2	ナベコ5X10	SCREW PAN M5X10	
14	S25456001	1	プランジヤピン	PLUNGER PIN	
15	SB4333101	1	イトハライリンククミ	THREAD WIPER LINK ASSY	
16	SB4213101	1	イトハライリンクササエ	THREAD WIPER LINK SUPPORT	
17	SB7015001	1	イトハライリンクCクミ	THREAD WIPER LINK C ASSY	
18	S07550001	1	リンクジク	LINK STUD	
19	SA2504001	1	セットカラー	SET SCREW COLLAR	
20	012500536	2	アナヒラ5X5	SET SCREW SOCKET (FT) M5X5	
21	SB4210001	1	ストツパ	STOPPER	
22	062500816	2	ナベコ5X8	SCREW PAN M5X8	
23	SB3849001	2	ヒラザガネチューウ5	WASHER_PLAIN_M_5	
24	S07552101	2	イトハライウケ	THREAD WIPER SUPPORT	
25	062661212	2	ナベコ318-40X12	SCREW PAN SM3.18-40X12	
26	SA2684001	1	イトハライバネ	THREAD WIPER SPRING	
27	062501016	2	ナベコ5X10	SCREW PAN M5X10	
28	SB4124001	2	イトハライ	THREAD WIPER	
29	S07424001	2	トメネジ3.18	SET SCREW, W/SOCKET SM3.18X4	
30	SB4211101	1	ソレノイドリンク	SOLENOID LINK	

S1. コントロールボックス 関係 / Control box

< 単相 230V AC 用 / For Single phase 230V AC >  
 < 欧州向用 / For Europe >

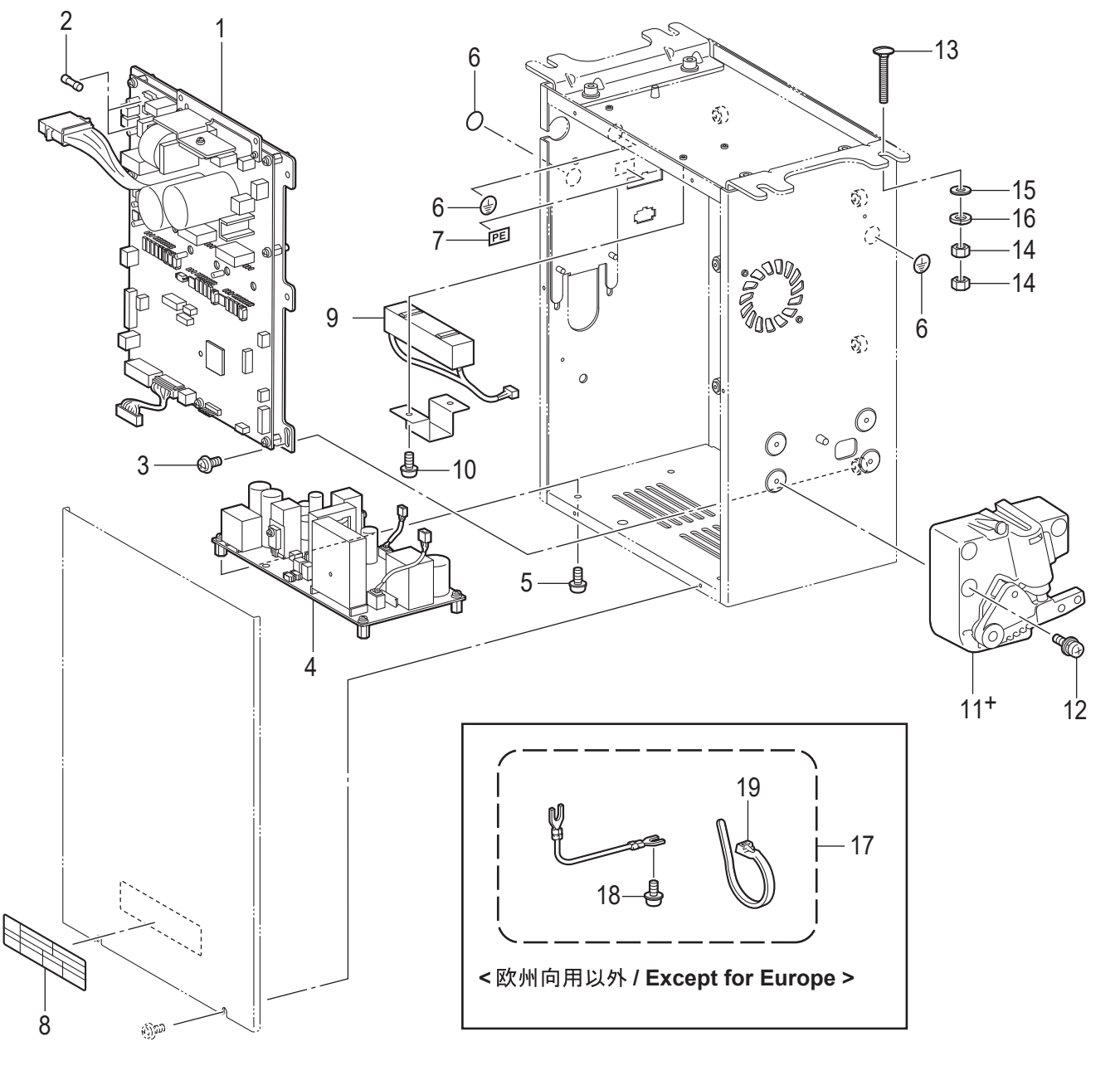
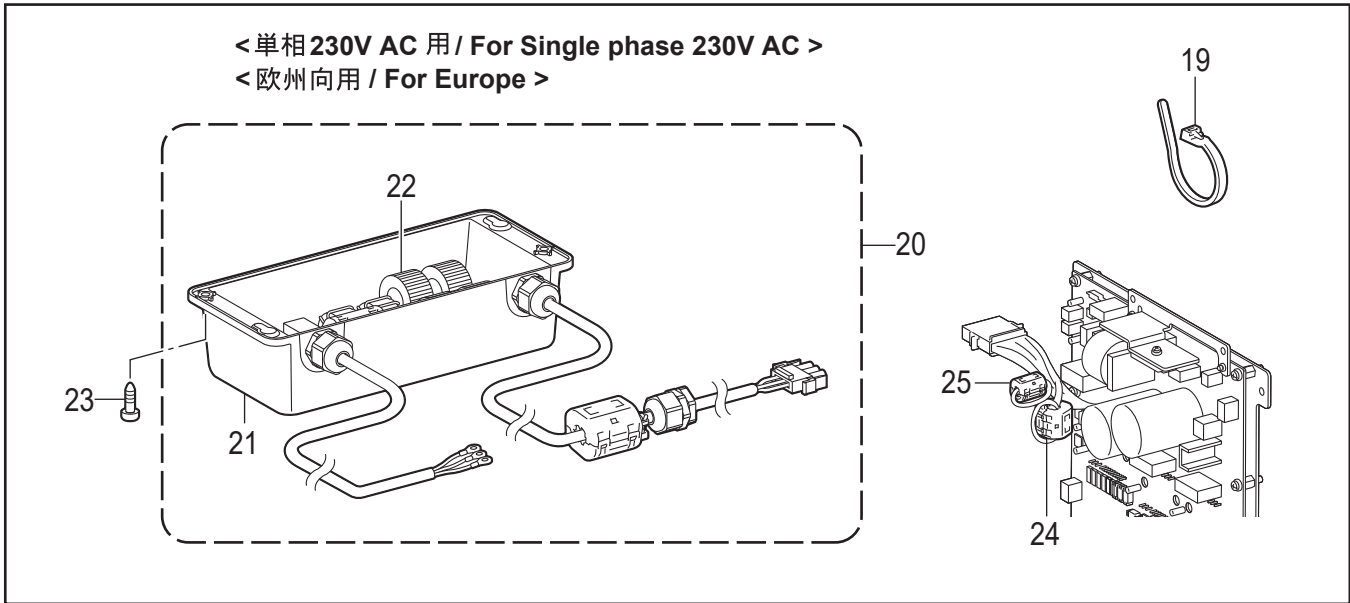

## S1. コントロールボックス関係 / Control box

REF.NO	CODE	Q'TY	品名	NAME OF PARTS	RM
1	SC0068001	1	メインキバンクミ84D	MAIN PCB ASSY 84D	
2	SB3275001	2	GFUSE10A	GLASS FUSE 10A-50T100H	
3	0A4400806	7	+ナベザクミ4X8DA	SCREW PAN (S/P WASHER) M4X8	
4	SC0069001	1	デンゲンキバンクミ84D	POWER PCB ASSY 84D	
5	0A5400806	4	+ナベザクミ4X8DB	SCREW PAN (S/P WASHER) M4X8	
6	S37060001	3	ア-スマーク	LABEL GROUNDING	
7	S37059001	1	PEマーク	LABEL, PE	
8	SB8096001	1	ラベルカンデン6カコク	LABEL ELECTRICAL SHOCK 36X150	
9	J04100001	1	セメントR40/220クミ#6	CEMENT RESISTOR ASSY 401220#6	
10	0A5400806	2	+ナベザクミ4X8DB	SCREW PAN (S/P WASHER) M4X8	
			<米州、欧州向用>	<For the Americas and Europe>	
11+	SB4587301	1	フミコミュニット-US <日本向用>	TREADLE UNIT-US <For Japan>	
			<アジア・一般・中国向用>	<For Asia, General and China>	
11+	SB3817401	1	フミコミュニット-EX	TREADLE UNIT-EX	
12	J00353001	4	+ナベセット5X14DB	SCREW PAN (S/P WASHER) M5X14	
13	SA9893001	4	カクネボルト8X65	BOLT M8X65	
14	021080206	8	2シュナット8	NUT 2 M8	
15	025080336	4	ヒラザガネダイ8	WASHER PLAIN L 8	
16	028080246	4	バネザガネ2-8	WASHER SPRING 2-8	
			<欧州向用以外>	<Except for Europe>	
17	SC0298001	1	ア-スコードネジタイクミ	EARTH CORD SCREW TIE ASSY	
18	0A4400806	1	+ナベザクミ4X8DA	SCREW PAN (S/P WASHER) M4X8	
19	J02825001	1	リピ-トタイRF140  <単相 230V AC用> <欧州向用>	REPEATE CABLE TIE, RF140  <For single phase 230V AC> <For Europe>	
20	SC0296001	1	CEフィルタクミTYPE8	CE FILTER UNIT TYPE8	
21	SB7074001	1	CEフィルターケース	CE FILTER CASE	
22	SB7065001	1	CEフィルタキバンクミ	CE FILTER PCB ASSY TYPE3	
23	S03816001	4	+マルモク45X16	WOOD SCREW M4.5X16	
24	SC0185001	1	コアGRFC-13	FERRITE CORE GRFC-13	
25	LNA409001	1	コアGRFC-6	FERRITE CORE GRFC-6	

## S2. コントロールボックス関係 / Control box

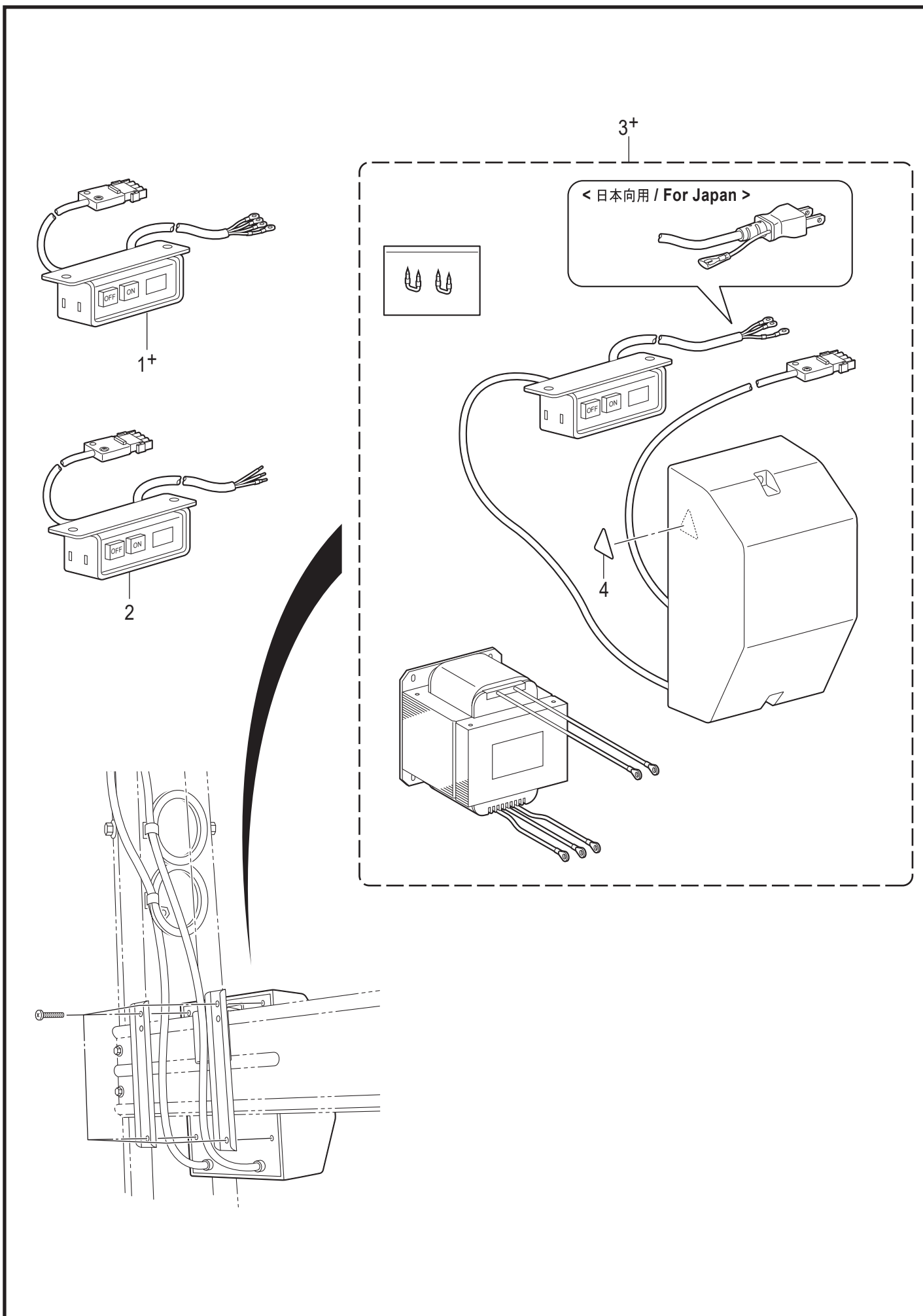

## S2. コントロールボックス関係 / Control box

REF.NO	CODE	Q'TY	品名	NAME OF PARTS	RM
1+	SA9616001	1	<三相 200V AC 用> <日本向用> デンSW クミ SJT	<For Three phase 200V AC> <For Japan> POWER SWITCH ASSY SJT	
1+	SA9831001	1	<三相 220V AC 用> <北米・メキシコ向用> デンSW クミ SJT#2	<For Three phase 220V AC> <For USA, Canada and Mexico> POWER SWITCH ASSY SJT#2	
2	SA9535001	1	<単相 220V AC用> <アジア・一般・中国向用> デンSWクミCCC	<For Single phase 220V AC> <For Asia, General and China> POWER SUPPLY SWITCH ASSY CCC	
3+	BMP3010-1000000-2ST1	1	<単相 100V用> <北米・メキシコ向用> トランスボックス	<For Single phase 100V> <For USA, Canada and Mexico> TRANSFORMER BOX	
3+	BMP3010-1000000-AST1	1	<日本向用> トランスボックス	<For Japan> TRANSFORMER BOX	
4	SA9914001	1	ラベルカンデン25X28	LABEL ELECTRICAL SHOCK 25X28	

T. 逆転スイッチ関係 / Quick reverse switch mechanism

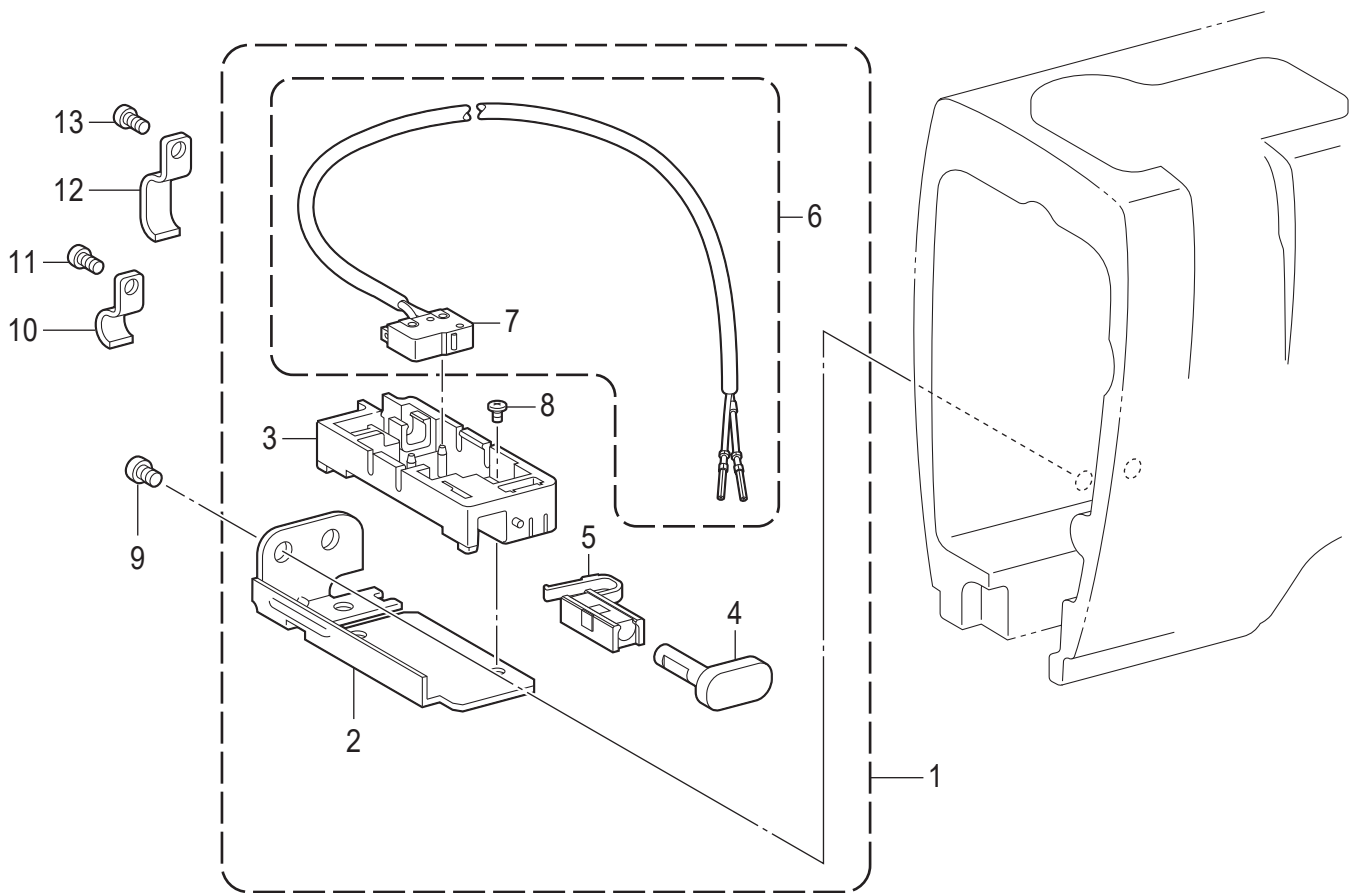



T . 逆転スイッチ関係 / Quick reverse switch mechanism

REF.NO	CODE	Q'TY	品名	NAME OF PARTS	RM
1	SB9882001	1	Rアクチュエータークミ	REVERSE ACTUATOR ASSY	
2	SA2270001	1	Rスイッチササエ	REVERSE SWITCH BRACKET	
3	SA7295001	1	Rスイッチダイ	REVERSE SWITCH BRACKET	
4	SB4123001	1	アクチュエーター	ACTUATOR	
5	SA4099001	1	Rスイッチバネ	REVERSE SWITCH SPRING	
6	SB9883001	1	Rスイッチクミ	R-SWITCH ASSY	
7	S32907050	1	マイクロスイッチ	MICRO SWITCH	
8	060300606	1	バインド3X6	SCREW BIND M3X6	
9	062500616	2	ナベコ5X6	SCREW PAN M5X6	
10	SA2689101	1	コードオサエ	CORD HOLDER	
11	062500616	1	ナベコ5X6	SCREW PAN M5X6	
12	SA1388101	3	コードオサエ	CORD HOLDER	
13	062500616	1	ナベコ5X6	SCREW PAN M5X6	

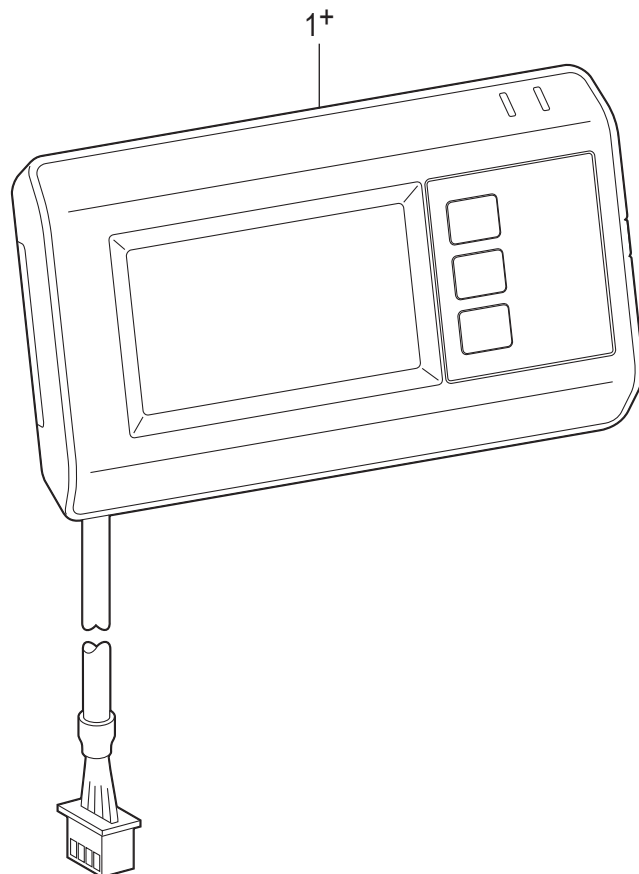

U. 操作パネル関係 / Operation panel

REF.NO	CODE	Q'TY	品名	NAME OF PARTS	RM
1+	SC0066001	1	<輸出一般向用> ソウサパネルクミ	<For General export> OPERATION PANEL ASSY	
1+	SC0066002	1	<輸出一般向用以外> ソウサパネルクミ	<Except for General export> OPERATION PANEL ASSY	

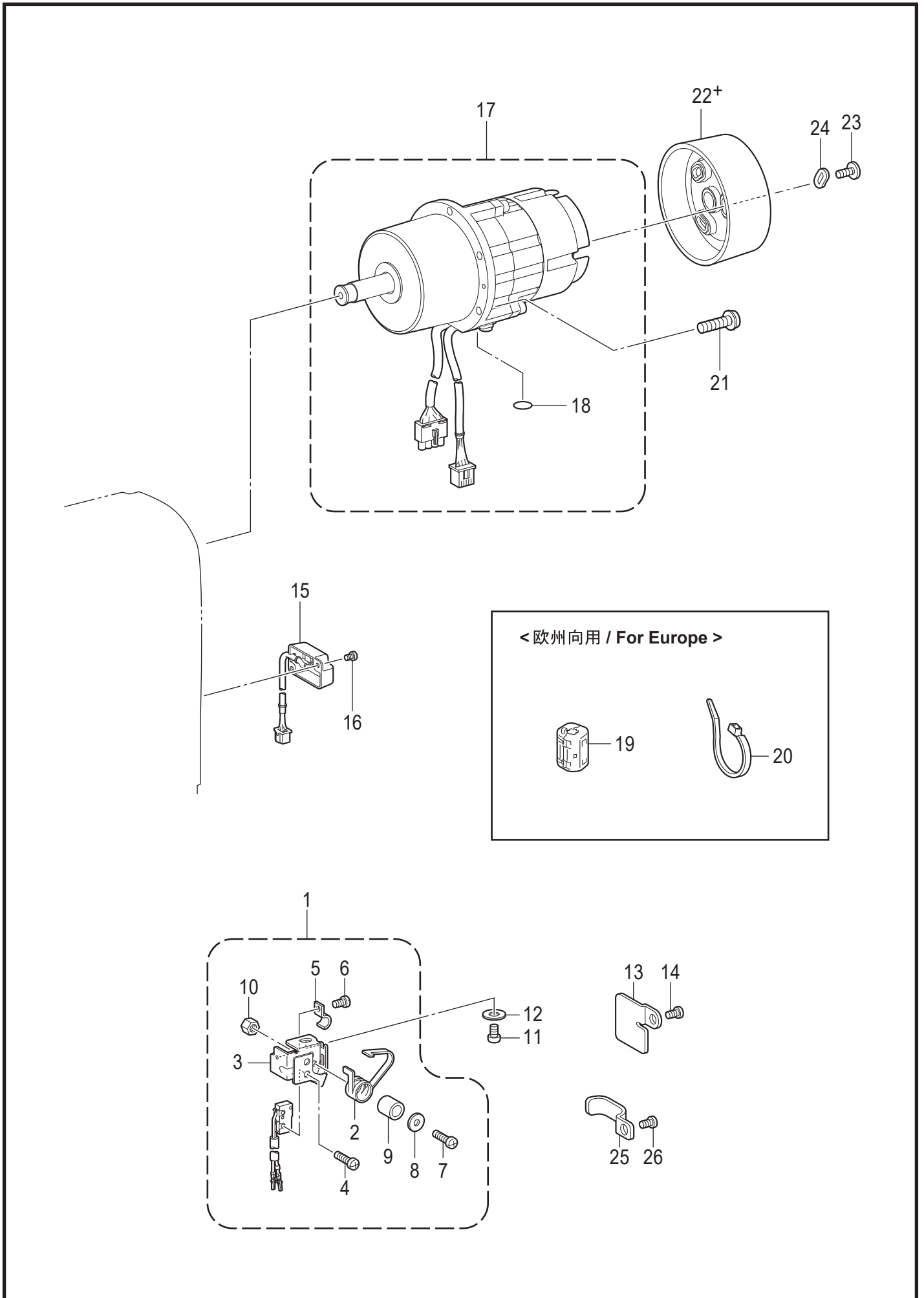

V. 電装品・モーター関係 / Power supply equipment and motor mechanism

REF.NO	CODE	Q'TY	品名	NAME OF PARTS	RM
1	SB9920001	1	セーフティスイッチクミ	SAFETY SWITCH ASSY	
2	S38744101	1	スイッチイタバネ	SWITCH PLATE SPRING	
3	SA2686001	1	スイッチダイ	SWITCH BASE	
4	062020806	2	ナベコ2X8	SCREW PAN M2X8	
5	140647101	1	コードオサエ	CORD HOLDER	
6	062400616	1	ナベコ4X6	SCREW PAN M4X6	
7	062401216	1	ナベコ4X12	SCREW PAN M4X12	
8	026040236	1	ヒラザガネミガキ4	WASHER PLAIN M 4	
9	154514001	1	スペーサー	SPACER	
10	021400106	1	1シュナット4	NUT 1 M4	
11	062060812	1	ナベコ6X8	SCREW PAN M6X8	
12	025060136	1	ヒラザガネシヨウ6	WASHER PLAIN S 6	
13	SA2712001	1	コードオサエ	CORD HOLDER	
14	062500816	1	ナベコ5X8	SCREW PAN M5X8	
15	SB9926101	1	ケンシュツホキユウT-8D	H-DETECTOR SUPPLY T-8D	
16	0A4501206	2	+ナベザクミ5X12DA	SCREW PAN (S/P WASHER) M5X12	
17	SB9775001	1	モータクミ 8400	MOTOR ASSY 8400	
18	S37060001	1	ア-スマーク	LABEL GROUNDING	
			<欧州向用>	<For Europe>	
19	SB8396001	1	フェライトKRFC-8	FERRITE CORE KRFC-8	
20	SB4155001	1	バンド	BAND	
21	SA2354001	5	+ナベセットネジ5X18	SCREW PAN M5X18	
22+	SB8940202	1	プーリ	PULLEY	
23	060501016	3	バインド5X10	SCREW BIND M5X10	
24	SA9452001	3	プーリワッシャー	PULLEY WASHER	
25	SA2687001	1	コードオサエ	CORD HOLDER	
26	062500816	1	ナベコ5X8	SCREW PAN M5X8	
			<-S0□用>	<For -S0□>	
22+	SB8940203	1	プーリ	PULLEY	

Z1. 付属品関係 / Accessories

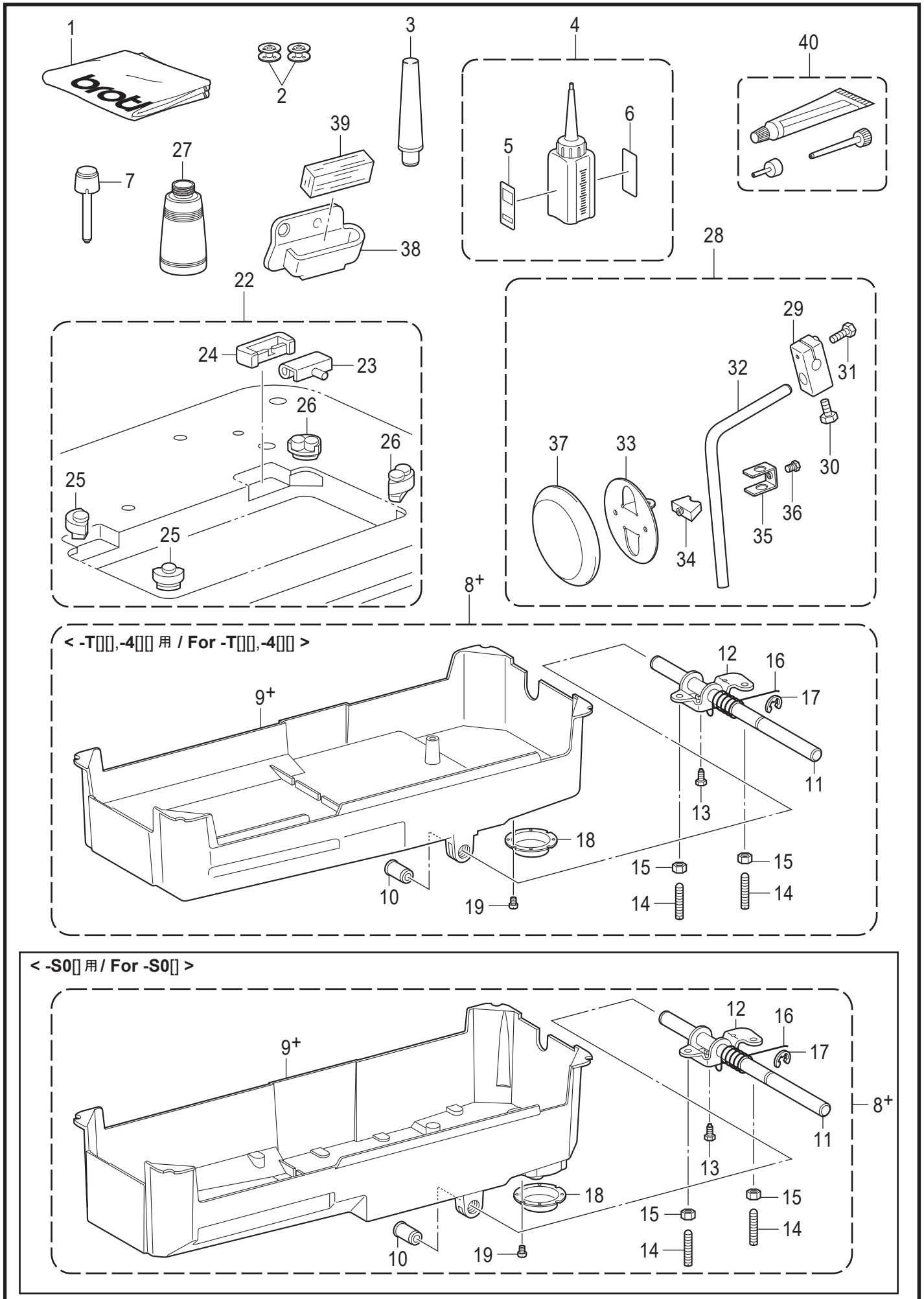

T-8421D/8422D-910

## Z1. 付属品関係 / Accessories

REF.NO	CODE	Q'TY	品名	NAME OF PARTS	RM
1	144226001	1	トубカバー	HEAD COVER	
2	S01928151	2	ボビン	BOBBIN	
3	100477009	1	マクラ	HEAD REST	
4	SA8239301	1	オイルタンククミ	OIL TANK ASSY	
5	SB1271101	1	オイルケイコクラベル ワブン	OIL WARNING LABEL JP	
6	SB1270001	1	オイルケイコクラベル エイブン	OIL WARNING LABEL EN	
7	145573000	1	ヒザアゲオシボウ	KNEE LIFTER COMPLYING BAR	
10	149578000	2	ヨコジクブツシュ	BUSH	
11	SA2582001	1	ヒザアゲヨコジク	KNEE LIFTER SHAFT	
12	SA2590001	1	ヒザアゲ	KNEE LIFTER	
13	S25344001	1	ボルト6	BOLT M6	
14	SB0687001	2	トメネジ6	SET SCREW M6X24	
15	021060306	2	3シュナット6	NUT 3 M6	
16	S15889001	1	ヒザアゲネジリバネ	TWIST SPRING	
17	146293001	1	トメワE10	RETAINING RING E10	
18	153230101	1	オイルニガシグチ	DRAIN	
19	S23418002	2	シメネジ4X5	SCREW M4X5	
22	SC0031001	1	ラバーヒンジクミ	RUBBER HINGE ASSY	
23	SB3627001	2	トубヒンジ	HEAD HINGE	
24	SB3628001	2	トубヒンジウケゴム	RUBBER CUSHION	
25	SA1962001	2	トубシキゴム	HEAD CUSHION	
26	SA1963001	2	トубシキゴム	HEAD CUSHION	
27	114486002	1	ポリオイラータイ	OILER	
28	SB3854101	1	ヒザアテクミ	KNEE LIFTER ASSY	
29	SB1603001	1	ヒザアテツギテ	KNEE LIFTER BRACKET	
30	SB1604001	1	ボルト6X15	BOLT 6X15	
31	SB1605001	1	ボルト6X24	BOLT 6X24	
32	SB3480001	1	ヒザアゲタテジク	KNEE LIFTER BAR	
33	SB1607001	1	ヒザアテ	KNEE LIFTER PLATE	
34	SB1608001	1	ヒザアテササエ	KNEE LIFTER SUPPORT	
35	SB1609001	1	ヒザアテストップ	KNEE LIFTER PLATE STOPPER	
36	SB1610001	1	ボルト6X12	BOLT 6X12	
37	SB1611001	1	ヒザアテカバー	KNEE LIFTER PLATE COVER	
38	SA2639001	1	<-4□3,-S03用> ア-ムイトアンナイD	<For -4□3,-S03> THREAD GUIDE, D: ARM	
39	114941001	1	ア-ムイトアンナイフェルト	FELT	
40	SB6659101	1	グリスクミ	GREASE UNIT	
8+	SA2691101	1	<-T□□,-4□□用> アブラウケクミ	<For -T□□,-4□□> OIL PAN ASSY	
9+	SA2692101	1	アブラウケ	OIL PAN	
8+	SC2414001	1	<-S0□用> アブラウケクミ	<For -S0□> OIL PAN ASSY	
9+	SC1855001	1	アブラウケ	OIL PAN	

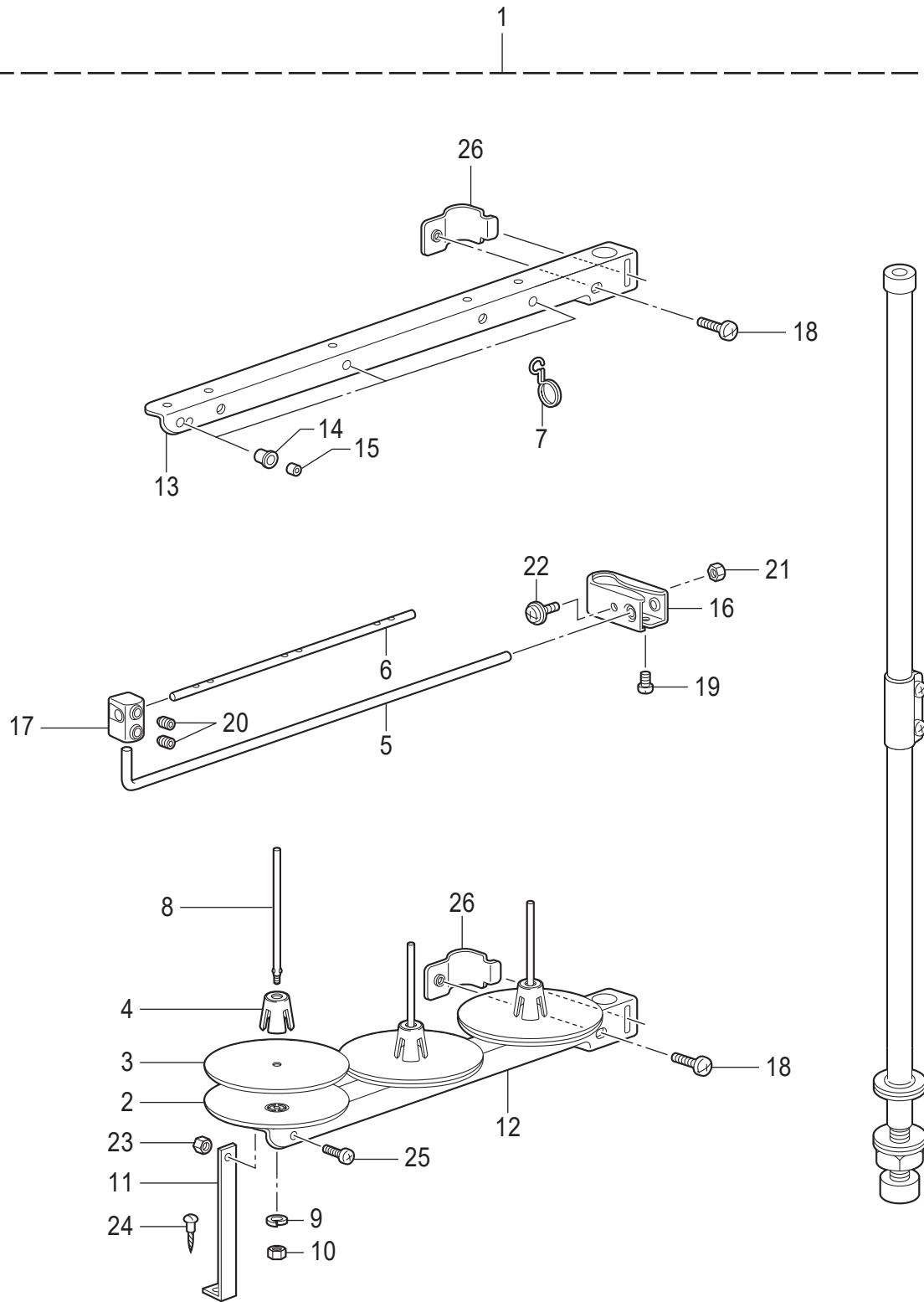







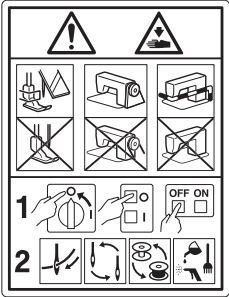

## Z2. 付属品関係 / Accessories

REF.NO	CODE	Q'TY	品名	NAME OF PARTS	RM
1	S07558509	1	イトタテダイクミ3DRTHF	COTTON STAND ASSY 3DRTHF	
2	S51283001	3	ウケザラ	SPOOL STAND BASE	
3	SB4114001	3	スプ-ルマット	SPOOL MAT	
4	S51282101	3	スプ-ルクツシヨン	SPOOL CUSHION	
5	S04109001	1	イトアンナイササエボウ	THREAD GUIDE SUPPORT BAR	
6	142997001	1	イトアンナイ3	THREAD GUIDE, 3	
7	S02747101	1	イトカケバネ	SPRING	
8	150179002	3	スプ-ルジクB	SPOOL SHAFT B	
9	SB4117001	3	バネザガネ2-5	WASHER SPRING 2-5	
10	SB4119001	3	2シュナツト5	NUT 2 M5	
11	150188009	1	スプ-ルホルダ-ササエA	SPOOL HOLDER SUPPORT A	
12	SA6610001	1	スプ-ルホルダ-3	SPOOL HOLDER 3	
13	SA6610001	1	スプ-ルホルダ-3	SPOOL HOLDER 3	
14	150183000	3	イトカケハンガ-ダイ	THREAD HANGER BASE	
15	142990001	3	スレツドブツシユ	THREAD BUSH	
16	SA6615001	1	イトアンナイホルダ-	THREAD GUIDE HOLDER	
17	138843201	1	ササエボウツギテ	JOINT	
18	062061603	2	ナベコ6X16	SCREW PAN M6X16	
19	062061003	1	ナベコ6X10	SCREW PAN M6X10	
20	014060632	2	アナクボミ6X6	SET SCREW SOCKET (CP) M6X6	
21	SB4119001	1	2シュナツト5	NUT, 2 M5	
22	S37037001	1	ナベコヒラザ5X32	SCREW PAN (S/P WASHER) M5X32	
23	SB4119001	1	2シュナツト5	NUT, 2 M5	
24	032461606	1	+2マルモク45X16	WOOD SCREW ROUND 2 M4.5X16	
25	062501003	1	ナベコ5X10	SCREW PAN M5X10	
26	SA6609001	2	スプ-ルホルダ-ササエ	SPOOL HOLDER SUPPORTER	

Wa. 警告ラベル / Warning labels

警告ラベル / Warning labels	品名 / Name of parts	Size(mm)	Code
	<p>ラベル感電6ヶ国 Label electrical shock 36 X 150</p>	<p>36 X 150</p>	<p>SB8096-101</p>
	<p>ラベル感電 25 X 28 Label electrical shock 25 X 28</p>	<p>L=28.4</p>	<p>SA9914-001</p>
	<p>操作注意ラベル Label caution</p>	<p>56 X 43</p>	<p>SA9826-001</p>
	<p>ワーニングマーク Injury mark</p>	<p>L=16</p>	<p>SA9957-001</p>
	<p>ワーニングマーク Injury mark</p>	<p>L=25</p>	<p>SA9957-002</p>
	<p>アースマーク Label grounding</p>	<p>φ 12</p>	<p>S37060-001</p>
	<p>PE マーク Label, PE</p>	<p>7.5 X 12.5</p>	<p>S37059-001</p>

Wa. 警告ラベル / Warning labels

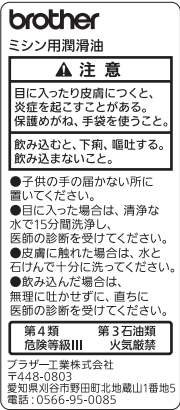
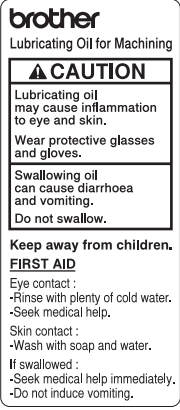
警告ラベル / Warning labels	品名 / Name of parts	Size(mm)	Code
	<p>オイル警告ラベル和文 Oil warning label JP</p>	<p>68 X 30</p>	<p>SB1271-101</p>
	<p>オイル警告ラベル英文 Oil warning label EN</p>	<p>68 X 30</p>	<p>SB1270-001</p>

**T-8421D (糸切りなし) / T-8421D (Without Thread trimmer)****■ かま / Rotary hooks**

かまは下記のオプションパーツを用意しています。用途に合わせてご使用ください。  
(部品コードは、かまが箱に入った組コードです)

The following types of rotary hook are available. Select whichever one is suitable for your application.  
(The following parts codes are assigned for the rotary hooks in the boxes.)

**● 標準 / Normal**

	-T03,-T□F用 / For -T03,-T□F
かま箱組 / Rotary hook assy	SB4618-101
調子バネ / Tension spring	151145-001
調子ネジ / Tension adjusting screw	151029-101

**● オプション / Option****○ キャップ付 / Rotary hook with cap**

	-T03,-T□F用 / For -T03,-T□F
かま箱組 / Rotary hook assy	SB4632-101
キャップ組 / Bobbin case assy	S07740-101
調子バネ / Tension spring	154518-001
調子ネジ / Tension adjusting screw	154519-101

**○ オープン給油 / Extra lubrication rotary hook**

かまへの油量が多いので、レース部の摩耗を防ぎます。厚物や極厚物の縫製に適しています。

Sufficient oil supplied to the rotary hook to prevent wear of the rotary hook race.

This type is suitable for sewing heavy and extra heavy materials.

	-T03用 / For -T03
かま箱組 / Rotary hook assy	SA1671-211
調子バネ / Tension spring	151145-001
調子ネジ / Tension adjusting screw	151029-101

**○ 剣先強化 / Rotary hook with reinforced hook point**

かまの剣先を強化し、剣先の摩耗を防ぎます。ループのできにくい素材（伸縮性のあるものなど）の縫製で、かまの剣先を針に接触させて使うような場合に適しています。

The rotary hook point is reinforced to improve its durability. This type is suitable for sewing materials that are hard to make loops on the surface ( like stretchy materials ), and that requires making contact with the hook point and the needles.

	-T03,-T□F用 / For -T03,-T□F
かま箱組 / Rotary hook assy	SA1673-111
調子バネ / Tension spring	151145-001
調子ネジ / Tension adjusting screw	151029-101

**T-8422D-40[],-S0[] (糸切り) / T-8422D-40[],-S0[] (With Thread trimmer)****■ かま / Rotary hooks**

かまは下記のオプションパーツを用意しています。用途に合わせてご使用ください。  
(部品コードは、かまが箱に入った組コードです)

The following types of rotary hook are available. Select whichever one is suitable for your application.  
(The following parts codes are assigned for the rotary hooks in the boxes.)

**● 標準 / Normal**

	-403,-405,-S03,-S05,-S07用 / For -403,-405,-S03,-S05,-S07
かま箱組 / Rotary hook assy	SA9781-101
調子バネ / Tension spring	151145-001
調子ネジ / Tension adjusting screw	151029-101

**● オプション / Option****○ キャップ付 / Rotary hook with cap**

	-403,-S03用 / For -403,-S03
かま箱組 / Rotary hook assy	SB4634-101
キャップ組 / Bobbin case assy	S07740-101
調子バネ / Tension spring	154518-001
調子ネジ / Tension adjusting screw	154519-101

**○ 剣先強化 / Rotary hook with reinforced hook point**

かまの剣先を強化し、剣先の磨耗を防ぎます。ループのできにくい素材（伸縮性のあるものなど）の縫製で、かまの剣先を針に接触させて使うような場合に適しています。

The rotary hook point is reinforced to improve its durability. This type is suitable for sewing materials that are hard to make loops on the surface ( like stretchy materials ), and that requires making contact with the hook point and the needles.

	-403,-S03用 / For -403,-S03
かま箱組 / Rotary hook assy	SA1679-111
調子バネ / Tension spring	151145-001
調子ネジ / Tension adjusting screw	151029-101

**T-8421D (糸切りなし) / T-8421D (Without Thread trimmer)**

標準品 / For normal

針幅 Needle gauge	針抱き組 Needle clamp assy	針板 Needle plate		送り歯 Feed dog	押え組 Presser foot assy
		中厚物用 (-T03) (最大5mmピッチ) For medium materials (Max 5mm pich)	オプション (最大4mmピッチ) Option (Max 4mm pich)	中厚物用 (-T03) For medium materials	
3.2mm	158794-101	117369-001		114951-001	S36544-001
4.8mm (3/16)	158791-101	117133-001		112659-001	SA4053-101
6.4mm (1/4)	158792-101	117367-001	112604-001	112660-001	SA4049-101
7.9mm (5/16)	158793-101	144882-001		112661-001	112645-001
9.5mm (3/8)	158798-101	144881-101		116510-101	116498-001
11.1mm (7/16)	158809-101		151596-001	151598-001	151597-101
25.4mm	158805-101		147176-001	147178-001	147177-101

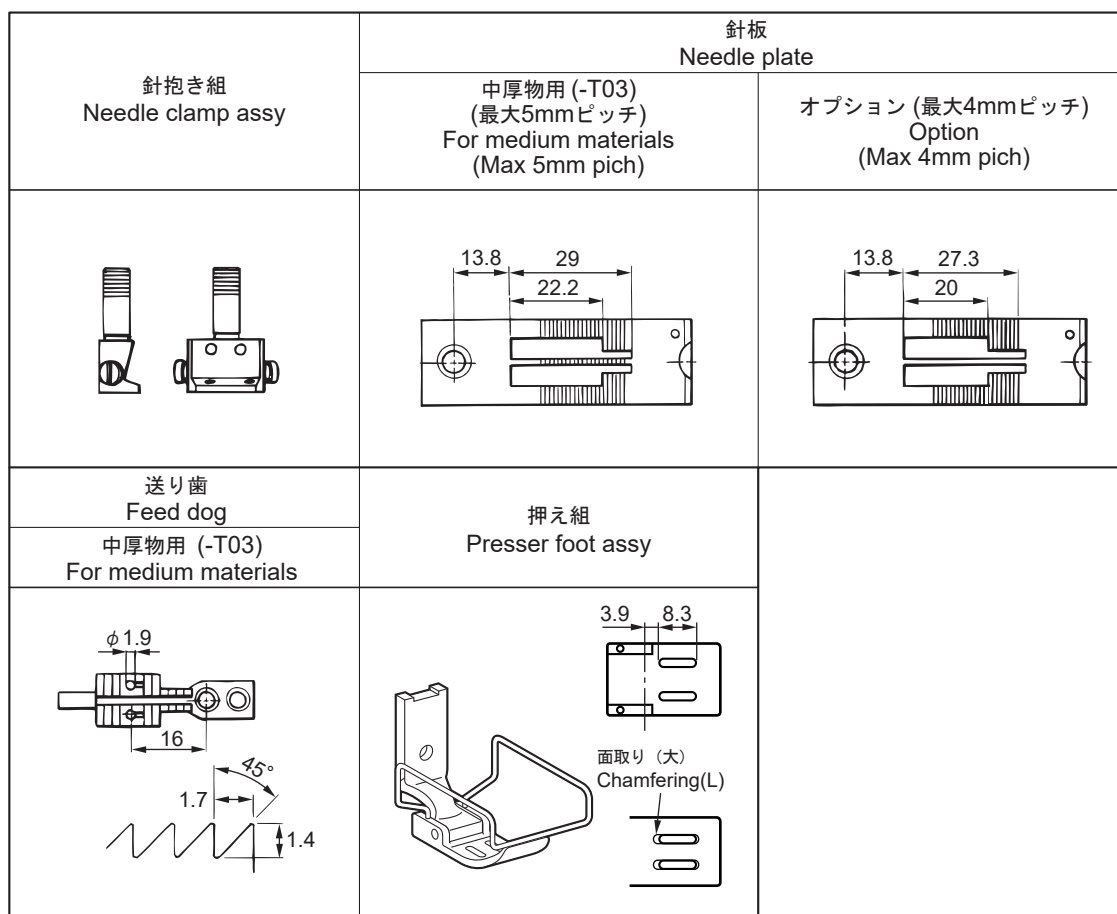

**T-8421D (糸切りなし) / T-8421D (Without Thread trimmer)**

**ファンデーション用 / For foundation**

- \* 針板と送り歯が標準品と異なります。針板取付用の皿ねじは117160-001(H-5)をご使用ください。
- \* The needle plate and the feed dog is different from normal parts.  
Use part no. 117160-001(H-5) as the needle plate installation screw.

針幅 Needle gauge	針抱き組 Needle clamp assy	針板 Needle plate	送り歯 Feed dog	押え組 Presser foot assy
4.8mm (3/16)	標準品 Normal	117158-001	117134-001	標準品 Normal

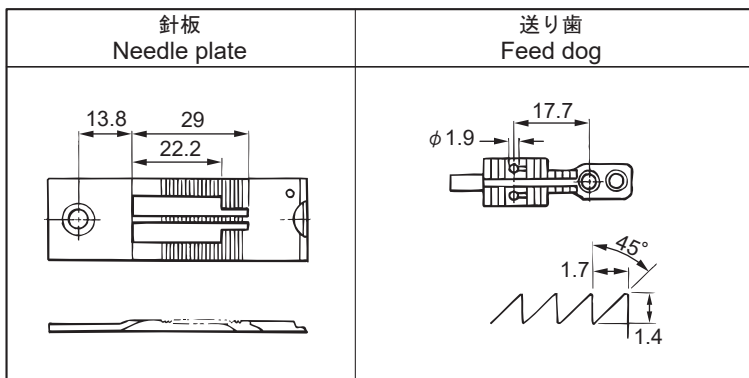

**空縫い用 / For sewing without material**

- \* 針板と送り歯と押え組が標準品と異なります。最大送りピッチは4mm以下でご使用ください。
- \* Needle plate, the feed dog and presser foot assembly is different from normal parts.  
Use gauge components of for sewing without material which have a maximum feed pitch of 4mm or less.

針幅 Needle gauge	針抱き組 Needle clamp assy	針板 Needle plate	送り歯 Feed dog	押え組 Presser foot assy
4.8mm (3/16)	標準品 Normal	S36010-101	S36011-101	S36012-001

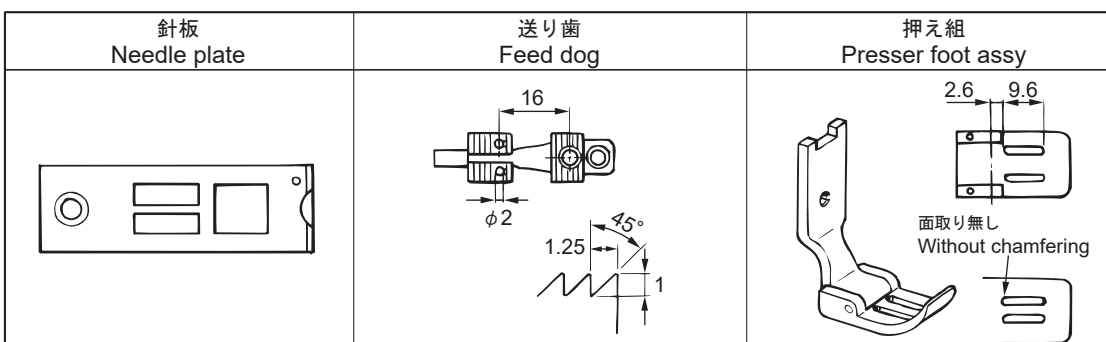

**T-8421D (糸切りなし) / T-8421D (Without Thread trimmer)**

**厚物用 / For heavy materials**

- \* 送り歯が標準品と異なります。
- \* The feed dog is different from normal parts.

針幅 Needle gauge	針抱き組 Needle clamp assy	針板 Needle plate	送り歯 Feed dog	押え組 Presser foot assy
6.4mm (1/4)	標準品 Normal	標準品 Normal	S21150-001	標準品 Normal

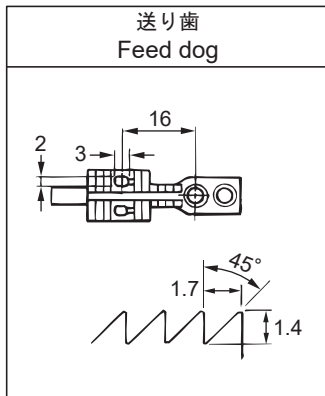

**極厚物用 / For extra heavy materials**

- \* 送り歯が標準品と異なります。
- \* The feed dog is different from normal parts.

針幅 Needle gauge	針抱き組 Needle clamp assy	針板 Needle plate	送り歯 Feed dog	押え組 Presser foot assy
3.2mm (1/8)	標準品 Normal	標準品 Normal	158430-001	標準品 Normal
4.8mm (3/16)			S13588-001	
6.4mm (1/4)			153882-001	

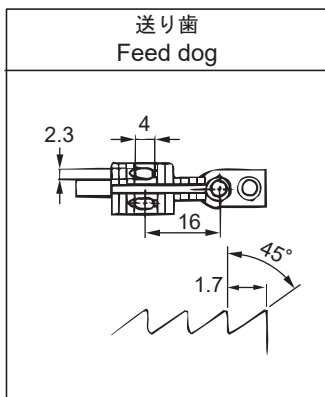



**T-8421D (糸切りなし) / T-8421D (Without Thread trimmer)**

オプション部品 / Option parts

\* 押え組が標準品と異なります。案内付押えは、最大送りピッチ4mm以下でご使用ください。

\* The presser foot assembly is different from normal parts.

The presser foot assembly with guide should be used with a maximum feed pitch of 4mm or less.

品名 Name of parts	針幅 Needle gauge	針抱き組 Needle clamp assy	針板 Needle plate	送り歯 Feed dog	押え組 Presser foot assy
案内付き押え組 Presser foot assy with guide	6.4mm (1/4)	標準品 Normal	標準品 Normal	標準品 Normal	149312-001

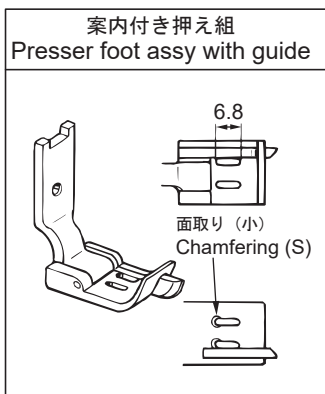

**T-8422D-40[] (糸切り) / T-8422D-40[] (With Thread trimmer)**

**標準品 / For normal**

\* 糸切り用固定刃(S07527-001)と取付ねじ(148539-101)は、針板に付いていません。必要に応じて別途ご注文ください。  
 \* The thread trimming fixed knife (part No. S07527-001) and the installation screw (part No. 148539-101) are not provided with the needle plate, so they must be ordered separately if required.

針幅 Needle gauge	針抱き組 Needle clamp assy	針板 Needle plate		送り歯 Feed dog		押え組 Presser foot assy	
		中厚, 厚物用 (-403,-405) (最大5mmピッチ) For medium & heavy materials (Max 5mm pich)	オプション (最大4mmピッチ) Option (Max 4mm pich)	中厚物用 (-403) For medium materials	厚物用 (-405) For heavy materials	中厚物用 (-403) For medium materials	厚物用 (-405) For heavy materials
3.2mm (1/8)	158794-101	155722-001	159400-001	148698-001	148699-001	S36550-001	
4.8mm (3/16)	158791-101	155851-001	158784-001	148702-001	148703-001	S36554-001	S36556-001
6.4mm (1/4)	158792-101	155853-001	158783-001	148704-101 *1	148705-001 158756-001 *2	SA4051-101	SA4050-101
7.9mm (5/16)	158793-101	155855-001		149692-001	149691-001	149689-001	149687-001
9.5mm (3/8)	158798-101	155857-001	149946-001	149939-001	149938-001	149942-001	149940-001
12.7mm (1/2)	158797-101	149677-001	159404-001	149676-001	149675-001	149673-201	
15.9mm (5/8)	158795-101	149954-001	149956-001	149949-001	149948-001		149950-101
19.1mm (3/4)	158806-101	150526-001			150523-001		150524-101
22.2mm (7/8)	158807-101	150534-001			150531-001		150532-101

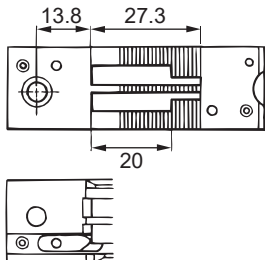
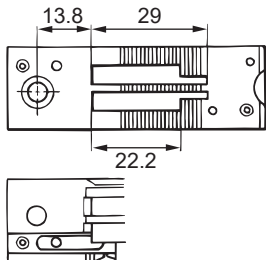
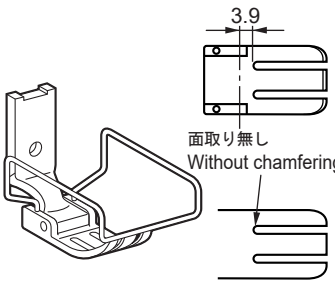
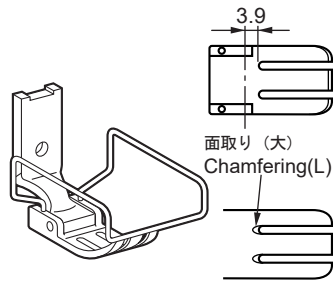
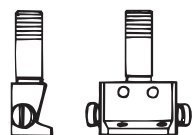
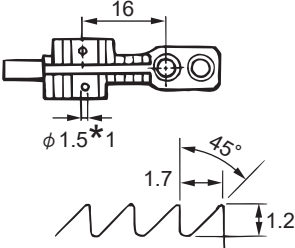
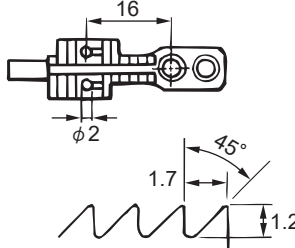
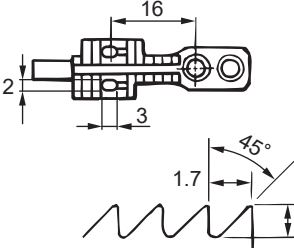
針板 Needle plate		押え組 Presser foot assy	
中厚物用 (-403) For medium materials	厚物用 (-405) For heavy materials	中厚物用 (-403) For medium materials	厚物用 (-405) For heavy materials
			
針抱き組 Needle clamp assy		送り歯 Feed dog	
	中厚物用 (-403) For medium materials	厚物用 (-405) For heavy materials	
			
	*1 (φ 1.7 : 148704-101のみ) (φ 1.7 : 148704-101 only)	148705-001	158756-001 *2 (中国向 : ジーンズ用) (For China : for denim)

**T-8422D-40[] (糸切り) / T-8422D-40[] (With Thread trimmer)**

**厚物用 / For heavy materials**

- \* 送り歯が標準品と異なります。
- \* The feed dog is different from normal parts.

針幅 Needle gauge	針抱き組 Needle clamp assy	針板 Needle plate	送り歯 Feed dog	押え組 Presser foot assy
4.8mm (3/16)	標準品 Normal	標準品 Normal	S07905-001	標準品 Normal
6.4mm (1/4)			158756-001	

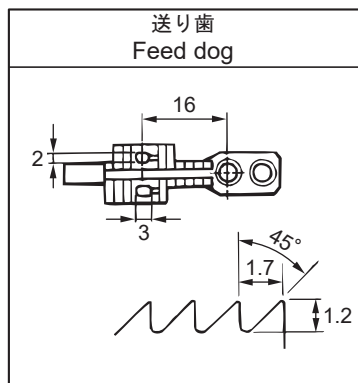

**下送り用 / For drop feed**

針幅 Needle gauge	針抱き組 Needle clamp assy	針板 Needle plate	送り歯 Feed dog	押え組 Presser foot assy
		薄物用 For light materials	薄物用 For light materials	薄物用 For light materials
6.4mm	標準品 Normal	S07405-001	S07411-001	S38543-001

針抱き組 Needle clamp assy	針板 Needle plate	送り歯 Feed dog	押え組 Presser foot assy
	薄物用 For light materials	薄物用 For light materials	薄物用 For light materials

T-8422D-S0[] (糸切り) / T-8422D-S0[] (With Thread trimmer)

標準品 / For normal

針幅 Needle gauge	針抱き組 Needle clamp assy	針板 Needle plate		送り歯 Feed dog		押え組 Presser foot assy	
		中厚, 厚物用 (-S03, -S05) (最大5mmピッチ) For medium & heavy materials (Max 5mm pitch)	オプション (最大4mmピッチ) Option (Max 4mm pitch)	中厚物用 (-S03) For medium materials	厚物用 (-S05) For heavy materials	中厚物用 (-S03) For medium materials	厚物用 (-S05) For heavy materials
3.2mm (1/8)	158794-101	SC2988-001	※お問い合わせください *Ask the place of purchase.	148698-001	148699-001	S36550-001	
4.8mm (3/16)	158791-101	SC2990-001		148702-001	148703-001	S36554-001	S36556-001
6.4mm (1/4)	158792-101	SC1622-001		148704-101*1	148705-001 158756-001*2	SA4051-101	SA4050-101
7.9mm (5/16)	158793-101	SC2992-001		149692-001	149691-001	149689-001	149687-001
9.5mm (3/8)	158798-101	SC2993-001		149939-001	149938-001	149942-001	149940-001
12.7mm (1/2)	158797-101	SC2994-001		149676-001	149675-001	149673-201	
15.9mm (5/8)	158795-101	SC2995-001		149949-001	149948-001		149950-101
19.1mm (3/4)	158806-101	SC2996-001			150523-001		150524-101
22.2mm (7/8)	158807-101	SC2997-001		150531-001		150532-101	

針板 Needle plate	押え組 Presser foot assy		針抱き組 Needle clamp assy
中厚, 厚物用 (-S03, -S05) For medium & heavy materials	中厚物用 (-S03) For medium materials	厚物用 (-S05) For heavy materials	
送り歯 Feed dog			
中厚物用 (-S03) For medium materials	厚物用 (-S05) For heavy materials		
<p>*1 (φ 1.7 : 148704-101のみ) (φ 1.7 : 148704-101 only)</p>	<p>148705-001</p>	<p>158756-001 *2 (中国向 : ジーンズ用) (For China : for denim)</p>	

**T-8422D-S0[] (糸切り) / T-8422D-S0[] (With Thread trimmer)**

**厚物用 / For heavy materials**

- \* 送り歯が標準品と異なります。
- \* The feed dog is different from normal parts.

針幅 Needle gauge	針抱き組 Needle clamp assy	針板 Needle plate	送り歯 Feed dog	押え組 Presser foot assy
4.8mm (3/16)	標準品 Normal	標準品 Normal	S07905-001	標準品 (-S05) Normal
6.4mm (1/4)			158756-001	

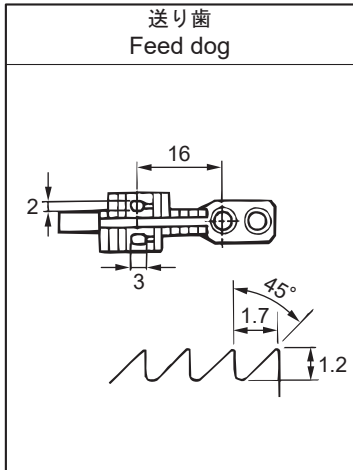

**T-8422D-S0[] (糸切り) / T-8422D-S0[] (With Thread trimmer)**

**極太糸用 / For extra thick thread**

針幅 Needle gauge	針抱き組 Needle clamp assy	針板 Needle plate	送り歯 Feed dog	押え組 Presser foot assy
6.4mm (1/4)	標準品 Normal	SC1623-001	SB0361-001	SB0359-001

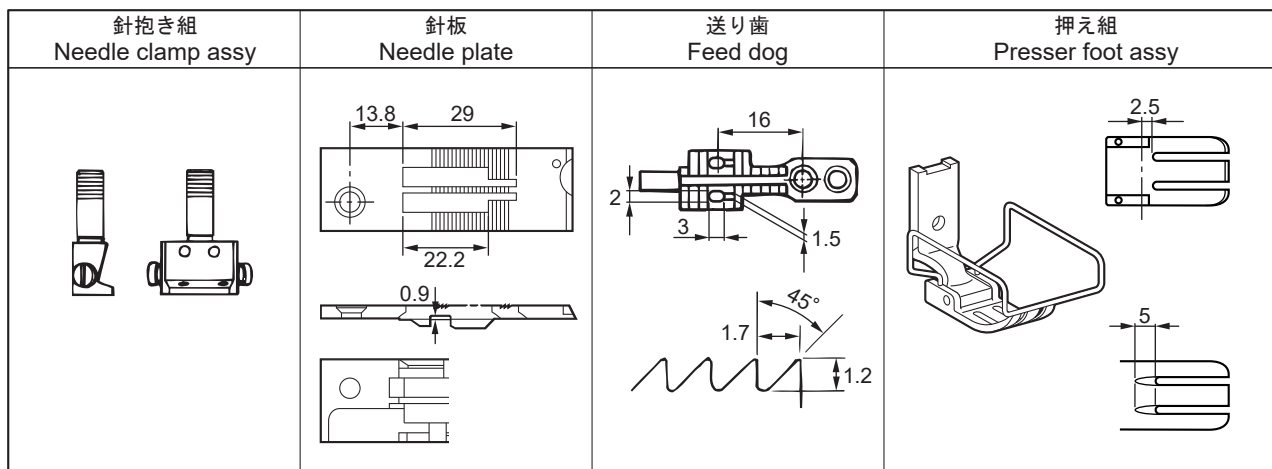

## 索引 / Index

CODE	REF.NO	Page	CODE	REF.NO	Page	CODE	REF.NO	Page	CODE	REF.NO	Page
004350616	M - 19	36	026040236	J2 - 90	26	062500616	T - 9	52	114941001	M - 49	36
	M - 37	36		V - 8	56		T - 11	52		Z1 - 39	58
012060636	C - 38	6	028040246	P - 62	40		T - 13	52	114951001	Ga1	65
	E - 33	10	028050246	P - 27	40	062500812	F - 5	12	115947101	J1 - 15	18
	F - 14	12	028080246	S1 - 16	48	062500816	A - 5	2		J2 - 54	22
	G - 7	14	032461606	Z2 - 24	60		A - 23	2		J2 - 54	26
	G - 26	14	048030342	D - 16	8		B - 34	4	116010001	A - 18	2
	M - 42	36	048040342	N - 2	38		B - 39	4	116323001	H - 2	16
	P - 31	40		N - 15	38		C - 16	6	116498001	Ga1	65
012061036	B - 32	4	048060142	F - 8	12		C - 30	6	116510101	Ga1	65
012061832	D - 18	8	048060342	E - 18	10		D - 2	8	116662003	P - 19	40
012300336	J2 - 77	26	048070342	P - 37	40		E - 40	10	117006001	B - 2	4
012400636	N - 9	38	048080342	E - 36	10		L - 9	32	117133001	Ga1	65
012500536	B - 8	4	060300606	T - 8	52		M - 40	36	117134001	Ga1	66
	B - 11	4	060400516	R - 12	46		Q - 3	44	117158001	Ga1	66
	D - 26	8	060400816	P - 61	40		R - 22	46	117160001	H - 5+	16
	M - 31	36	060501016	V - 23	56		V - 14	56	117367001	Ga1	65
	N - 14	38	062020806	V - 4	56		V - 26	56	117369001	Ga1	65
	P - 5	40	062060812	V - 11	56	062501003	Z2 - 25	60	118550001	J2 - 70	26
	R - 20	46	062060816	E - 7	10	062501016	E - 3	10	118735002	C - 34	6
012501031	J1 - 36	18		E - 46	10		P - 8	40	118954000	E - 10	10
	J2 - 26	20		L - 39	32		P - 18	40	138843201	Z2 - 17	60
	J2 - 26	24		P - 12	40		R - 13	46	140063001	A - 1	2
014060632	Z2 - 20	60		Q - 5	44		R - 27	46	140327001	L - 63	34
014300432	G - 37	14	062061003	Z2 - 19	60	062501216	A - 7	2	140647101	V - 5	56
016061031	E - 30	10	062061012	P - 10	40		D - 29	8	140890009	L - 56	32
	F - 12	12	062061016	F - 6	12		E - 42	10	141544001	J2 - 44	20
017401415	J2 - 89	26		J1 - 21	18		E - 47	10	142274201	L - 31	32
017500812	P - 52	40		J2 - 60	22	062661212	R - 25	46	142990001	Z2 - 15	60
018062032	C - 33	6		L - 58	34	081004070	L - 27	32	142997001	Z2 - 6	60
	C - 43	6	062061603	Z2 - 18	60	081038070	L - 21	32	143611201	E - 8	10
	E - 15	10	062061616	C - 31	6	0A4400806	L - 36	32	143612100	E - 9	10
	F - 16	12		P - 38	40		S1 - 3	48	143613051	E - 16	10
018062532	C - 40	6	062300416	G - 23	14		S1 - 18	48	143616001	E - 17	10
018401036	C - 23	6	062300612	J1 - 39	18	0A4501206	V - 16	56	144226001	Z1 - 1	58
018401236	N - 18	38		J2 - 29	20	0A5400806	S1 - 5	48	144504001	M - 27	36
018501232	J2 - 48	20		J2 - 29	24		S1 - 10	48	144881101	Ga1	65
	J2 - 48	24	062300616	M - 39	36	0A5501006	L - 24	32	144882001	Ga1	65
021060306	D - 19	8		R - 6	46	100328001	E - 26	10	145446002	M - 23	36
	D - 37	8	062350516	M - 22	36	100477009	Z1 - 3	58	145573000	Z1 - 7	58
	P - 47	40	062350816	C - 26	6	104450101	L - 20	32	146293001	Z1 - 17	58
	Z1 - 15	58	062351216	P - 21	40		L - 35	32	147176001	Ga1	65
021080206	S1 - 14	48	062400616	G - 18	14		L - 51	32	147177101	Ga1	65
021300106	M - 11	36		G - 33	14	104821001	E - 39	10	147178001	Ga1	65
021350106	G - 15	14		J1 - 45	18	105234003	P - 34	40	148394000	C - 28	6
	P - 22	40		J1 - 46	18	108549001	E - 24	10	148536001	P - 56	42
021400106	V - 10	56		J1 - 49	18		N - 4	38	148539101	P - 58	42
021500106	D - 30	8		J2 - 35	20	108801001	L - 49	32	148546001	P - 14	40
	E - 48	10		J2 - 35	24	108802001	G - 5	14	148559100	P - 35	40
	P - 28	40		J2 - 36	20	108960002	A - 27	2	148602001	J2 - 63	22
021500316	J1 - 33	18		J2 - 36	24	109405001	L - 48	32		J2 - 63	26
	J2 - 23	20		J2 - 39	20	110161004	Q - 1	44	148698001	Ga2	69
	J2 - 23	24		J2 - 39	24	112604001	Ga1	65		Ga2	71
025030132	G - 22	14		L - 54	32	112645001	Ga1	65	148699001	Ga2	69
025060132	G - 13	14		V - 6	56	112659001	Ga1	65		Ga2	71
025060136	J1 - 22	18	062400812	J2 - 42	20	112660001	Ga1	65	148702001	Ga2	69
	J2 - 61	22	062400816	P - 66	42	112661001	Ga1	65		Ga2	71
	N - 16	38	062401216	V - 7	56	112728001	C - 27	6	148703001	Ga2	69
	V - 12	56	062401616	L - 44	32	112753001	L - 57	32		Ga2	71
025060236	L - 59	34	062500616	A - 11	2	113014000	B - 3	4	148704101	Ga2	69
025080336	S1 - 15	48		C - 6	6	113050001	H - 7	16		Ga2	71
025100132	E - 37	10		L - 47	32	113431002	P - 26	40	148705001	Ga2	69
026030233	R - 7	46		N - 28	38	114486002	Z1 - 27	58		Ga2	71

CODE	REF.NO	Page	CODE	REF.NO	Page	CODE	REF.NO	Page	CODE	REF.NO	Page
148743001	L - 64	34	154518001	Sp	63	S01928151	Z1 - 2	58	S25260001	C - 11	6
149095001	F - 17	12		Sp	64	S02747101	Z2 - 7	60		C - 20	6
149312001	Ga1	68	154519101	Sp	63	S03816001	S1 - 23	48	S25289001	D - 9	8
149578000	Z1 - 10	58		Sp	64	S04109001	Z2 - 5	60	S25344001	Z1 - 13	58
149673201	Ga2	69	154560101	M - 28	36	S06696004	J2 - 75	26	S25456001	R - 14	46
	Ga2	71	154730001	F - 2	12	S07346101	D - 6+	8	S31006002	D - 11	8
149675001	Ga2	69	154731000	F - 3	12	S07349001	D - 24	8	S32907050	T - 7	52
	Ga2	71	154965001	J1 - 38	18	S07350001	D - 38	8	S34438001	A - 17	2
149676001	Ga2	69		J2 - 28	20	S07351001	D - 14	8	S36010101	Ga1	66
	Ga2	71		J2 - 28	24	S07353001	D - 13	8	S36011101	Ga1	66
149677001	Ga2	69	155510001	M - 29	36	S07355051	D - 27+	8	S36012001	Ga1	66
149687001	Ga2	69	155722001	Ga2	69	S07374102	E - 49	10	S36544001	Ga1	65
	Ga2	71	155851001	Ga2	69	S07376001	E - 44	10	S36550001	Ga2	69
149689001	Ga2	69	155853001	Ga2	69	S07405001	Ga2	70		Ga2	71
	Ga2	71	155855001	Ga2	69	S07411001	Ga2	70	S36554001	Ga2	69
149691001	Ga2	69	155857001	Ga2	69	S07419001	J1 - 27	18		Ga2	71
	Ga2	71	158430001	Ga1	67		J2 - 18	20	S36556001	Ga2	69
149692001	Ga2	69	158756001	Ga2	69		J2 - 18	24		Ga2	71
	Ga2	71		Ga2	70	S07420000	J1 - 26	18	S36663101	A - 16+	2
149938001	Ga2	69		Ga2	71		J2 - 17	20	S37037001	Z2 - 22	60
	Ga2	71		Ga2	72		J2 - 17	24	S37059001	S1 - 7	48
149939001	Ga2	69	158783001	Ga2	69	S07424001	R - 29	46		Wa	61
	Ga2	71	158784001	Ga2	69	S07465000	C - 8	6	S37060001	A - 21	2
149940001	Ga2	69	158791101	Ga1	65	S07494001	H - 9	16		S1 - 6	48
	Ga2	71		Ga2	69	S07509001	P - 36	40		V - 18	56
149942001	Ga2	69		Ga2	71	S07525100	J2 - 43	20		Wa	61
	Ga2	71	158792101	Ga1	65	S07526301	P - 55	42	S38212001	J1 - 37	18
149946001	Ga2	69		Ga2	69	S07527001	P - 57	42		J2 - 27	20
149948001	Ga2	69		Ga2	71	S07529001	D - 15	8		J2 - 27	24
	Ga2	71	158793101	Ga1	65	S07550001	R - 18	46	S38266000	L - 11	32
149949001	Ga2	69		Ga2	69	S07552101	R - 24	46	S38274001	M - 32	36
	Ga2	71		Ga2	71	S07558509	Z2 - 1	60	S38543001	Ga2	70
149950101	Ga2	69	158794101	Ga1	65	S07740101	Sp	63	S38687000	P - 64	42
	Ga2	71		Ga2	69		Sp	64	S38713100	B - 27	4
149954001	Ga2	69		Ga2	71	S07905001	Ga2	70	S38744101	V - 2	56
149956001	Ga2	69	158795101	Ga2	69		Ga2	72	S39051001	D - 12	8
150179002	Z2 - 8	60		Ga2	71	S09260001	J1 - 25+	18	S39830101	E - 28	10
150183000	Z2 - 14	60	158797101	Ga2	69		J2 - 16+	20	S48247001	J2 - 79	26
150188009	Z2 - 11	60		Ga2	71		J2 - 16+	24	S50098201	E - 25	10
150523001	Ga2	69	158798101	Ga1	65	S09261001	J1 - 25+	18	S51282101	Z2 - 4	60
	Ga2	71		Ga2	69		J2 - 16+	20	S51283001	Z2 - 2	60
150524101	Ga2	69		Ga2	71		J2 - 16+	24	SA1120001	B - 19	4
	Ga2	71	158805101	Ga1	65	S11244001	H - 4	16	SA1179001	D - 23	8
150526001	Ga2	69	158806101	Ga2	69	S13160001	B - 6	4		D - 33	8
150531001	Ga2	69		Ga2	71	S13588001	Ga1	67		D - 35	8
	Ga2	71	158807101	Ga2	69	S15889001	Z1 - 16	58	SA1360101	N - 27	38
150532101	Ga2	69		Ga2	71	S16196001	D - 6+	8	SA1388101	T - 12	52
	Ga2	71	158809101	Ga1	65	S20681000	M - 25	36	SA1671211	Sp	63
150534001	Ga2	69	159400001	Ga2	69	S20682111	M - 26	36	SA1673111	Sp	63
151027101	J3 - 5	28	159404001	Ga2	69	S21150001	Ga1	67	SA1679111	Sp	64
151029101	Sp	63	159805001	M - 24	36	S23418002	N - 20	38	SA1962001	Z1 - 25	58
	Sp	64	228475000	L - 14	32		Z1 - 19	58	SA1963001	Z1 - 26	58
151030101	J3 - 4	28	BMP3010-1000000-2ST1			S23460001	C - 36	6	SA1981301	N - 11	38
151145001	Sp	63		S2 - 3+	50	S23651001	B - 20	4	SA1982101	N - 12	38
	Sp	64	BMP3010-1000000-AST1				B - 25	4	SA1983201	N - 13	38
151596001	Ga1	65		S2 - 3+	50		G - 9	14	SA1984001	N - 17	38
151597101	Ga1	65	J00353001	S1 - 12	48		J2 - 47	20	SA1985001	N - 19	38
151598001	Ga1	65	J02825001	S1 - 19	48		K - 11	30	SA1990101	N - 23	38
153132000	F - 18	12	J04100001	S1 - 9	48	S25235001	B - 21	4	SA1992101	N - 26	38
153138001	F - 9	12	LNA409001	S1 - 25	48	S25236001	B - 22	4	SA2165001	D - 34	8
153230101	Z1 - 18	58	S01928151	J1 - 23	18		E - 13	10	SA2190001	N - 25	38
153882001	Ga1	67		J2 - 62	22		P - 41	40	SA2270001	T - 2	52
154514001	V - 9	56		J2 - 62	26	S25260001	B - 18	4	SA2354001	V - 21	56

## 索引 / Index

CODE	REF.NO	Page	CODE	REF.NO	Page	CODE	REF.NO	Page	CODE	REF.NO	Page
SA2378001	P - 40	40	SA2556001	J2 - 53	22	SA2630001	M - 21	36	SA2929001	A - 4	2
SA2404001	B - 28	4		J2 - 53	26	SA2632001	M - 30	36		A - 19	2
SA2441201	A - 6	2		J2 - 57	22	SA2633001	M - 33	36		A - 20	2
SA2443101	A - 10	2		J2 - 57	26	SA2634001	M - 36	36		L - 10	32
SA2444101	A - 12	2	SA2560001	J1 - 31	18	SA2635001	M - 38	36		L - 19	32
SA2445101	A - 13	2		J2 - 22	20	SA2636001	M - 41	36	SA2935201	B - 5	4
SA2448201	A - 14+	2		J2 - 22	24	SA2637001	M - 43	36	SA2956001	L - 5	32
SA2450201	A - 15+	2	SA2562201	J1 - 2	18	SA2638001	M - 44	36	SA2957001	L - 6	32
SA2452101	B - 14	4		J2 - 2	20		M - 50	36	SA2958001	B - 10	4
SA2460101	B - 23	4		J2 - 2	24	SA2639001	M - 48	36	SA2992001	F - 7	12
SA2461001	B - 26	4	SA2563301	J1 - 8	18		Z1 - 38	58		F - 13	12
SA2462001	B - 40	4		J2 - 9+	20	SA2640001	M - 45	36	SA3040001	L - 2	32
SA2463001	B - 31	4	SA2565001	J1 - 17	18		M - 47	36		L - 17	32
SA2464101	B - 9	4		J2 - 56	22	SA2643001	P - 2	40		L - 33	32
SA2469101	B - 33	4		J2 - 56	26	SA2644001	P - 3	40	SA3044001	L - 40	32
SA2475101	C - 24	6	SA2566001	G - 14	14	SA2645001	P - 4	40	SA3045201	L - 37	32
SA2481001	C - 18	6	SA2567001	J1 - 19	18		P - 54	40	SA3046001	L - 38	32
SA2485001	C - 10	6		J2 - 58	22	SA2646001	P - 6	40	SA3048101	L - 52	32
	C - 19	6	SA2568001	J1 - 20	18	SA2647001	P - 9	40	SA3049001	L - 53	32
SA2486101	C - 29	6		J2 - 59	22	SA2648001	P - 11	40	SA3054001	J1 - 3	18
SA2489001	C - 32	6	SA2571101	K - 5	30	SA2651001	P - 13	40		J2 - 3	20
SA2490101	C - 35	6	SA2572201	J1 - 40	18	SA2652101	P - 15	40		J2 - 3	24
SA2493001	C - 41	6		J2 - 30	20	SA2655001	P - 20	40	SA3055101	L - 7	32
SA2494001	C - 42	6		J2 - 30	24	SA2657001	P - 29	40		L - 18	32
SA2495001	D - 1	8	SA2574001	J1 - 41	18	SA2658001	P - 30	40		L - 41	32
SA2498001	D - 8	8		J1 - 44	18	SA2663001	P - 42+	42	SA3056101	E - 21	10
SA2499001	D - 10	8		J2 - 31	20	SA2665001	P - 44+	42	SA3058101	B - 36	4
SA2500001	D - 20	8		J2 - 31	24	SA2667001	P - 46+	42	SA3059101	B - 38	4
SA2501001	D - 21	8		J2 - 34	20	SA2668001	P - 48	40	SA3060001	L - 34	32
SA2502001	D - 22	8		J2 - 34	24	SA2669001	P - 49	40	SA3062001	E - 1+	10
SA2504001	D - 25	8	SA2575001	K - 7	30	SA2670101	J2 - 13	20	SA3065001	B - 37	4
	R - 19	46	SA2575101	J1 - 42	18	SA2671001	J2 - 6	20	SA3414101	M - 2+	36
SA2506001	D - 31	8		J2 - 32	20	SA2672001	P - 50+	42	SA3415001	M - 2+	36
SA2507001	D - 32	8		J2 - 32	24	SA2673001	P - 51+	42	SA3416101	M - 2+	36
SA2509001	E - 1+	10	SA2579001	J1 - 9	18	SA2675001	J2 - 46	20	SA3417501	M - 1+	36
SA2511001	E - 2	10		J2 - 10	20	SA2676001	J2 - 41	20	SA3710001	C - 25	6
SA2512001	E - 4	10		J2 - 10	24	SA2677201	D - 17	8	SA3711101	C - 3	6
SA2515001	E - 5	10	SA2580101	K - 6+	30	SA2678001	Q - 2	44	SA3712001	C - 4	6
SA2516001	E - 6	10	SA2582001	Z1 - 11	58	SA2679001	Q - 4	44	SA3840001	G - 10+	14
SA2518001	E - 11	10	SA2584001	K - 8	30	SA2684001	R - 26	46	SA3848001	C - 7	6
SA2521001	E - 14	10	SA2585001	E - 12	10	SA2686001	V - 3	56	SA3852001	C - 9	6
SA2523001	E - 27	10		K - 10	30	SA2687001	V - 25	56	SA3855001	G - 1	14
SA2525001	E - 29	10		K - 14	30	SA2689101	T - 10	52	SA3859101	J1 - 30	18
SA2526001	E - 31	10	SA2587101	K - 12	30	SA2691101	Z1 - 8+	58		J2 - 21	20
SA2529101	E - 35	10	SA2590001	Z1 - 12	58	SA2692101	Z1 - 9+	58		J2 - 21	24
SA2530001	E - 38	10	SA2604001	L - 45	32	SA2712001	V - 13	56	SA3887001	G - 20	14
SA2531001	E - 50	10	SA2605001	L - 46	32	SA2717001	J2 - 40	20	SA3888001	G - 21	14
SA2532001	E - 41	10	SA2606101	L - 50	32	SA2722001	J1 - 16	18	SA3889101	J1 - 34	18
SA2533001	E - 45	10	SA2607501	M - 1+	36		J2 - 55	22		J2 - 24	20
SA2535101	F - 4	12	SA2613101	M - 4	36		J2 - 55	26		J2 - 24	24
SA2536001	F - 10	12	SA2614201	M - 5	36	SA2723001	L - 22	32	SA3890001	K - 1	30
SA2539001	F - 15	12	SA2615001	M - 6	36	SA2724001	G - 34	14	SA3891001	K - 3	30
SA2540001	F - 11	12	SA2619001	M - 7	36		L - 23	32	SA3894001	J1 - 48	18
SA2541001	E - 52	10	SA2620001	M - 9	36	SA2728001	P - 7	40		J2 - 38	20
SA2543001	G - 4	14	SA2621001	M - 10	36	SA2759101	K - 6+	30		J2 - 38	24
SA2544001	G - 6	14	SA2623201	M - 8	36	SA2806101	G - 30	14	SA3912001	J2 - 45	20
SA2546001	G - 8	14	SA2624001	M - 13	36	SA2818501	M - 1+	36	SA3924001	A - 2	2
SA2551001	G - 25	14	SA2625001	M - 14	36	SA2824001	M - 20	36	SA3946001	L - 4	32
SA2553001	G - 16	14	SA2626001	M - 12	36	SA2826001	J2 - 64+	22	SA3965001	G - 2	14
SA2554001	G - 17	14		M - 15	36	SA2860001	P - 16	40	SA3990001	G - 19	14
SA2555001	G - 27+	14	SA2627001	M - 16	36	SA2861101	B - 4	4	SA4007001	C - 5	6
SA2556001	J1 - 14	18	SA2628001	M - 17	36	SA2927001	G - 12	14	SA4009001	G - 32	14
	J1 - 18	18	SA2629001	M - 18	36	SA2928001	G - 28	14	SA4011001	G - 35	14



CODE	REF.NO	Page	CODE	REF.NO	Page	CODE	REF.NO	Page	CODE	REF.NO	Page
SA4012001	J1 - 47	18	SA6394001	P - 25	40	SA9914001	Wa	61	SB4155001	R - 8	46
	J2 - 37	20	SA6395001	P - 17	40	SA9957001	A - 24	2		V - 20	56
	J2 - 37	24	SA6411001	L - 70	34		Wa	61	SB4193001	J1 - 29	18
SA4026001	J1 - 35	18	SA6412001	L - 69	34	SA9957002	A - 25	2		J2 - 20	20
	J2 - 25	20	SA6413001	L - 71	34		Wa	61		J2 - 20	24
	J2 - 25	24	SA6414001	L - 62	34	SA9977101	A - 9	2	SB4195001	D - 7	8
SA4028001	G - 3	14	SA6415001	L - 30	32	SB0359001	Ga2	72	SB4197001	C - 37	6
SA4029001	J1 - 24	18	SA6416001	L - 61	34	SB0361001	Ga2	72	SB4198001	C - 39	6
	J2 - 15	20	SA6417001	J1 - 13	18	SB0687001	Z1 - 14	58	SB4210001	R - 21	46
	J2 - 15	24		J2 - 52	22	SB1270001	Wa	62	SB4211101	R - 30	46
SA4033101	L - 13	32		J2 - 52	26		Z1 - 6	58	SB4213101	R - 16	46
SA4038001	J1 - 25+	18	SA6422001	L - 67	34	SB1271101	Wa	62	SB4333101	R - 15	46
	J2 - 16+	20	SA6423001	L - 29	32		Z1 - 5	58	SB4587301	S1 - 11+	48
	J2 - 16+	24		L - 60	34	SB1423001	C - 2	6	SB4608001	L - 43	32
SA4044001	J1 - 5	18	SA6424201	J1 - 4	18	SB1425001	C - 22	6	SB4618101	Sp	63
	J2 - 5	20		J2 - 4	20	SB1429001	C - 15	6	SB4632101	Sp	63
	J2 - 5	24		J2 - 4	24	SB1450001	P - 32	40	SB4634101	Sp	64
SA4045001	J1 - 11	18	SA6425201	J1 - 10	18	SB1452001	P - 33	40	SB4823201	J1 - 1	18
	J2 - 12	20		J2 - 11	20	SB1485001	B - 16	4	SB4824201	J1 - 7	18
	J2 - 12	24		J2 - 11	24	SB1535001	B - 17	4	SB4827301	J2 - 1+	20
SA4049101	Ga1	65	SA6462001	J1 - 6	18		K - 9	30	SB4828301	J2 - 8+	20
SA4050101	Ga2	69		J2 - 7	20	SB1536001	B - 24	4	SB6659101	Z1 - 40	58
	Ga2	71		J2 - 7	24		K - 13	30	SB7015001	R - 17	46
SA4051101	Ga2	69	SA6463001	J1 - 12	18	SB1603001	Z1 - 29	58	SB7065001	S1 - 22	48
	Ga2	71		J2 - 14	20	SB1604001	Z1 - 30	58	SB7074001	S1 - 21	48
SA4053101	Ga1	65		J2 - 14	24	SB1605001	Z1 - 31	58	SB7507001	E - 34	10
SA4089001	B - 15	4	SA6465001	L - 65	34	SB1607001	Z1 - 33	58	SB8096001	S1 - 8	48
SA4093301	C - 14	6	SA6467001	L - 66	34	SB1608001	Z1 - 34	58	SB8096101	Wa	61
SA4094001	C - 17	6	SA6468001	L - 28	32	SB1609001	Z1 - 35	58	SB8396001	V - 19	56
SA4095001	C - 21	6	SA6470101	L - 68	34	SB1610001	Z1 - 36	58	SB8436001	P - 65	42
SA4099001	T - 5	52	SA6472001	L - 42	32	SB1611001	Z1 - 37	58	SB8940202	V - 22+	56
SA4112101	B - 7	4	SA6473001	L - 55	32	SB2245002	N - 1	38	SB8940203	V - 22+	56
SA4115101	B - 12	4	SA6474001	J1 - 28	18	SB2246001	N - 21	38	SB9775001	V - 17	56
SA4129101	B - 13	4		J2 - 19	20	SB2247001	N - 5	38	SB9859001	A - 3	2
SA4149101	D - 36	8		J2 - 19	24	SB2265002	D - 3	8	SB9863001	A - 8	2
SA4205101	L - 1	32	SA6475001	L - 26	32	SB2275001	N - 6	38	SB9865001	E - 19	10
SA4212001	M - 3	36	SA6592001	E - 51	10	SB2330001	J1 - 32	18	SB9867001	E - 20	10
SA4213001	K - 15	30	SA6609001	Z2 - 26	60		J2 - 51	22	SB9882001	T - 1	52
SA4215101	L - 12	32	SA6610001	Z2 - 12	60		J2 - 51	26	SB9883001	T - 6	52
SA4444001	J1 - 25+	18		Z2 - 13	60	SB3275001	S1 - 2	48	SB9907001	P - 1	40
	J2 - 16+	20	SA6615001	Z2 - 16	60	SB3480001	Z1 - 32	58	SB9910001	R - 1	46
	J2 - 16+	24	SA7235001	R - 3	46	SB3571101	N - 29	38	SB9911001	F - 1	12
SA4458001	J2 - 64+	22	SA7295001	T - 3	52	SB3627001	Z1 - 23	58	SB9920001	V - 1	56
SA4494001	E - 23	10	SA7607101	D - 5	8	SB3628001	Z1 - 24	58	SB9926101	V - 15	56
SA4506001	M - 34	36	SA8239301	Z1 - 4	58	SB3817401	S1 - 11+	48	SC0031001	Z1 - 22	58
SA4507001	M - 35	36	SA8364001	P - 59	40	SB3848001	P - 63	40	SC0066001	U - 1+	54
SA4537001	B - 35	4	SA8503001	N - 10	38	SB3849001	E - 43	10	SC0066002	U - 1+	54
SA4585001	K - 2	30	SA8507001	N - 8	38		P - 53	40	SC0068001	S1 - 1	48
	K - 4	30	SA8508001	N - 3	38		R - 23	46	SC0069001	S1 - 4	48
SA5026101	L - 3	32	SA8509001	N - 24	38	SB3854101	Z1 - 28	58	SC0185001	S1 - 24	48
	L - 16	32	SA8512101	N - 22	38	SB4104001	R - 11	46	SC0296001	S1 - 20	48
SA5304001	L - 15	32	SA8893101	C - 1	6	SB4105001	R - 10	46	SC0298001	S1 - 17	48
SA5332001	C - 12	6	SA8982202	N - 30	38	SB4114001	Z2 - 3	60	SC0568001	H - 5+	16
SA6150101	G - 11+	14	SA9452001	V - 24	56	SB4117001	Z2 - 9	60	SC0694001	G - 10+	14
SA6152101	G - 11+	14	SA9535001	S2 - 2	50	SB4119001	Z2 - 10	60	SC0697001	G - 11+	14
SA6166001	B - 1	4	SA9563001	N - 7	38		Z2 - 21	60	SC0700201	J2 - 1+	24
SA6178001	L - 8	32	SA9616001	S2 - 1+	50		Z2 - 23	60	SC0702001	J2 - 71	26
SA6307201	J1 - 51	18	SA9781101	Sp	64	SB4123001	T - 4	52	SC0704001	J2 - 9+	24
	J2 - 50	20	SA9826001	A - 22	2	SB4124001	R - 28	46	SC0706001	J2 - 72	26
	J2 - 50	24		Wa	61	SB4125001	E - 32	10	SC0707001	J2 - 73	26
SA6308001	G - 31	14	SA9831001	S2 - 1+	50	SB4126001	G - 24+	14	SC0708101	J2 - 74	26
SA6392001	P - 23	40	SA9893001	S1 - 13	48	SB4152001	P - 39+	42	SC0709001	J2 - 76	26
SA6393001	P - 24	40	SA9914001	S2 - 4	50	SB4155001	P - 67	42	SC0711001	J2 - 80	26

## 索引 / Index

CODE	REF.NO	Page	CODE	REF.NO	Page	CODE	REF.NO	Page	CODE	REF.NO	Page
SC0712001	J2 - 84	26									
SC0713201	J2 - 8+	24									
SC0715001	J2 - 94	26									
SC0716001	J2 - 95	26									
SC0717101	J2 - 96	26									
SC0718001	A - 26	2									
SC0719001	J2 - 98	26									
SC0720001	J2 - 83	26									
SC0721001	J2 - 82	26									
SC0722001	P - 39+	42									
SC0724001	P - 46+	42									
SC0726001	P - 51+	42									
SC0727001	P - 50+	42									
SC0728001	J2 - 85	26									
SC0729001	J2 - 88	26									
SC0730001	J2 - 91	26									
SC0731001	J2 - 92	26									
SC0732001	G - 27+	14									
SC0733001	G - 24+	14									
SC0736001	P - 42+	42									
SC0743001	P - 44+	42									
SC0746001	A - 14+	2									
SC0747001	A - 15+	2									
SC0748001	A - 16+	2									
SC0941001	J2 - 99	26									
SC1622001	Ga2	71									
SC1623001	Ga2	72									
SC1762001	J2 - 97	26									
SC1855001	Z1 - 9+	58									
SC2408001	J2 - 86	26									
SC2414001	Z1 - 8+	58									
SC2988001	Ga2	71									
SC2990001	Ga2	71									
SC2992001	Ga2	71									
SC2993001	Ga2	71									
SC2994001	Ga2	71									
SC2995001	Ga2	71									
SC2996001	Ga2	71									
SC2997001	Ga2	71									
SC3881001	J2 - 78	26									
SC4017001	J2 - 87	26									
	J2 - 93	26									



# brother

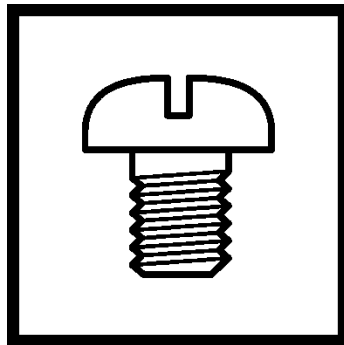

パーツブック  
PARTS BOOK

**ブラザー工業株式会社** <http://www.brother.co.jp/>

〒448-0803 刈谷市野田町北地蔵山1番地5 TEL:0566-95-0085

**BROTHER INDUSTRIES, LTD.** <http://www.brother.com/>

1-5, Kitajizoyama, Noda-cho, Kariya 448-0803, Japan. Phone : 81-566-95-0088